

Voltage selector switch, 3 stages, step switch, panel mounting



Description

- Voltage Selector, 3 stages
- Step switch
- Solder terminals

Standards

- IEC 61058-2-5
- UL 508
- CSA C22.2 no. 55

References

Alternative: version for PCB mounting [SWM2 \(Print\)](#)

Weblinks

[pdf-datasheet](#), [html-datasheet](#), [General Product Information](#), [Approvals](#), [CE declaration of conformity](#), [RoHS](#), [CHINA-RoHS](#), [e-Shop](#), [SCHURTER-Stock-Check](#), [Distributor-Stock-Check](#), [CAD-Drawings](#), [Mounting instruction](#), [Detailed request for product](#)

Technical Data

Ratings	IEC: 6.3 A / 250 VAC; 50 Hz UL: 10 A / 250 VAC; 60 Hz CSA: 10 A / 250 VAC; 60 Hz
Mounting	Panel Mount from front side
Fastening	Screw-on mounting
Terminal	Solder
Number of Stages	3
Lifetime	300 operating cycles (without load)
Degree of Protection	IP 40
Protection Class	Suitable for appliances with protection class II acc. to IEC 61140
Allowable Operation Temp.	-40 °C to 85 °C
Climatic Category	25/85/21 acc. to IEC 60068-1
Material: Socket	Thermoplastic, black, UL 94V-0
Weight	6.5 g

Solderability	350 °C / 2 sec acc. to IEC 60068-2-20, Test Ta, method 2
Resistance to Soldering Heat	350 °C / 10 sec acc. to IEC 60068-2-20, Test Tb, method 2
Insulation Resistance	> 10'000MΩ (500VDC; 1min)
Contact Resistance	< 10 mΩ at 20 mV
Dielectric Strength	> 2kVAC between L-N > 4kVAC between L/N-PE (1min; 50Hz)
Clearance and Creepage Distance	> 3mm > 8mm between L/N-PE
Resistance to Vibration	acc. to IEC 60068-2-6, test Fc
Panel Thickness s	max 8 mm

Dimension

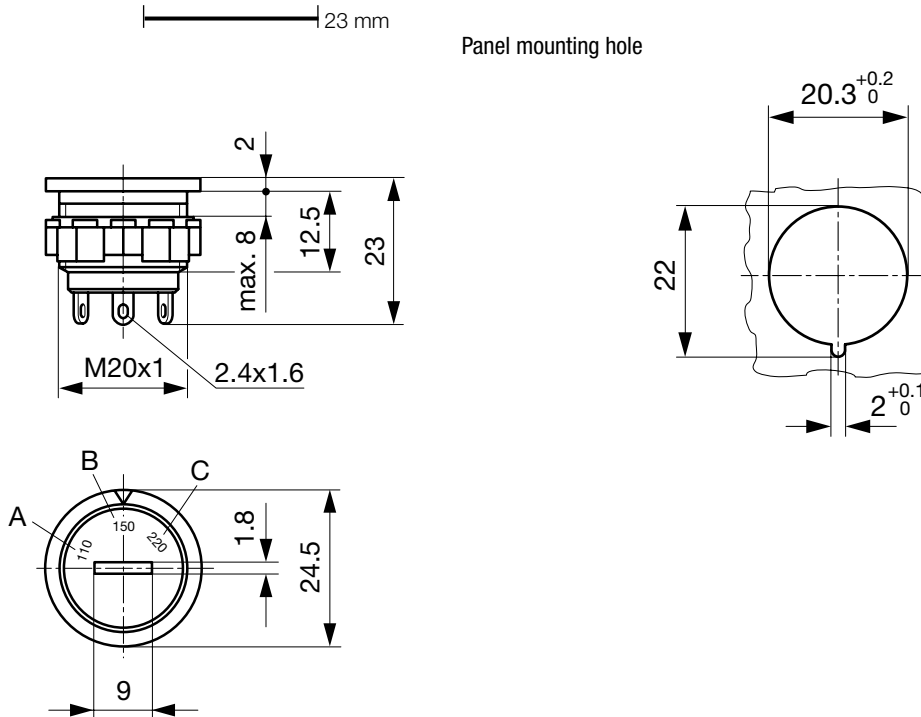

Diagrams

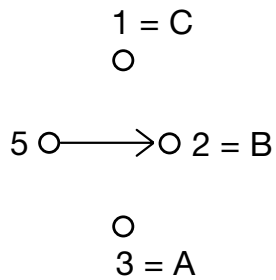

Variants

Marking			Order Number
A	B	C	
110	150	220	0033.4001
110	220	240	0033.4002
220	240		0033.4003
200	220	240	0033.4004
220	240	250	0033.4006
100	115	230	0033.4008
220	230	240	0033.4011
			0033.4014
115	220	240	0033.4019
220 V	230 V	240 V	0033.4028
4	8	16	0033.4032
100	110	230	0033.4040
115	0	230	0033.4044

Marking			Order Number
A	B	C	
230	240	250	0033.4049
115 V	230 V	240 V	0033.4055
1	2	3	0033.4056
100	120	230-240	0033.4057
110		230	0033.4062

Most Popular.

Availability for all products can be searched real-time:<http://www.schurter.com/en/Stock-Check/Stock-Check-SCHURTER>

Packaging Unit 50 Pcs