

Voltage selector switch, 2 stages, serie-parallel, PCB mounting



### Description

- Voltage Selector, 2 stages
- Series-parallel connections
- PCB terminals

### Standards

- IEC 61058-2-5
- UL 508
- CSA C22.2 no. 55

### References

Alternative: version for panel mounting [SWA1 \(Frontpl\)](#)

### Weblinks

[pdf-datasheet](#), [html-datasheet](#), [General Product Information](#), [Approvals](#), [CE declaration of conformity](#), [RoHS](#), [CHINA-RoHS](#), [e-Shop](#), [SCHURTER-Stock-Check](#), [Distributor-Stock-Check](#), [CAD-Drawings](#), [Mounting instruction](#), [Detailed request for product](#)

### Technical Data

Ratings	IEC: 6.3 A / 250 VAC; 50 Hz UL: 6.3 A / 250 VAC; 60 Hz CSA: 6.3 A / 250 VAC; 60 Hz
Mounting	PCB Mounting
Terminal	Solder, THT
Number of Stages	2
Lifetime	300 operating cycles (without load)
Degree of Protection	from front side IP 40
Protection Class	Suitable for appliances with protection class II acc. to IEC 61140
Allowable Operation Temp.	-40 °C to 85 °C
Climatic Category	25/85/21 acc. to IEC 60068-1
Material: Socket	Thermoplastic, black, UL 94V-0
Weight	3.9 g

Solderability	235 °C / 2 sec acc. to IEC 60068-2-20, Test Ta, method 1
Resistance to Soldering Heat	260 °C / 5 sec acc. to IEC 60068-2-20, Test Tb, method 1A
Insulation Resistance	> 10'000MΩ (500VDC; 1min)
Contact Resistance	< 10 mΩ at 20 mV
Dielectric Strength	> 2kVAC between L-N > 4kVAC between L/N-PE (1min; 50Hz)
Clearance and Creepage Distance	> 3mm > 8mm between L/N-PE
Resistance to Vibration	acc. to IEC 60068-2-6, test Fc

### Dimension

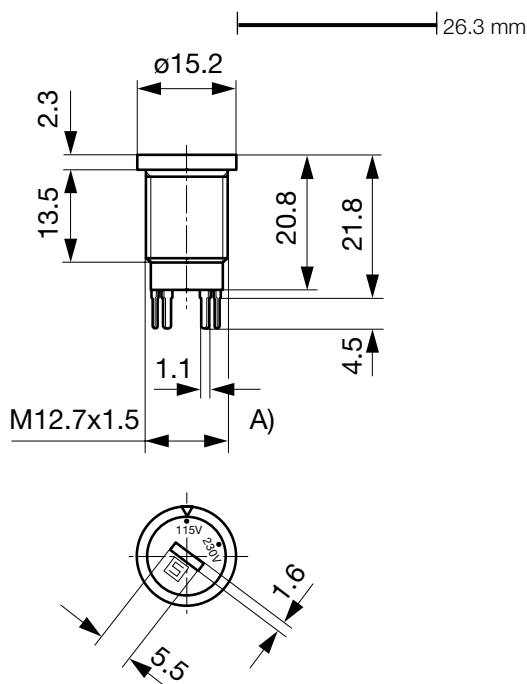

### Drilling diagram

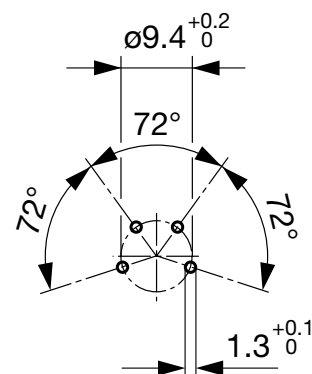

A) double start thread

## Diagrams

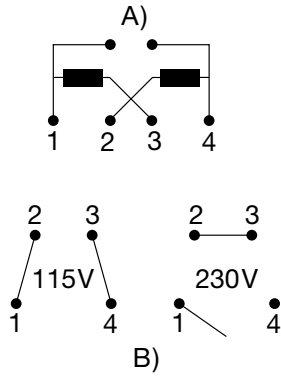

A) Power mains

B) Internal contact arrangement for series-parallel connection

## Variants

Letterings		Order Number
Stage 1	Stufe 2	
110	220	0033.4601
120	240	0033.4603
115	230	0033.4604
230	240	0033.4610
		0033.4614
120	230	0033.4615
100	230	0033.4619

Most Popular.

Availability for all products can be searched real-time: <http://www.schurter.com/en/Stock-Check/Stock-Check-SCHURTER>

**Packaging Unit**

100 Pcs