

iC-SN85 BLCC SN2C

INFRARED LED



Rev B1, Page 1/7

FEATURES

- ◆ Emission peak at 850 nm matched to silicon sensors
- ◆ Optimized irradiance pattern
- ◆ High temperature range -40 to 125 °C
- ◆ High optical output power
- ◆ Fast switching speed
- ◆ Isolated backside

APPLICATIONS

- ◆ Illumination for high resolution optical encoder
- ◆ Modulated light barriers

PACKAGES

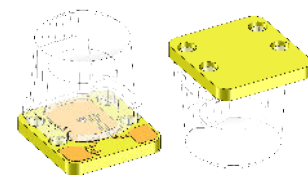

BLCC SN2C

PACKAGING INFORMATION (top view)

PIN CONFIGURATION SN2C

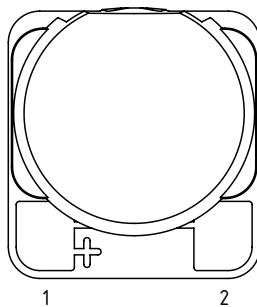

PIN FUNCTIONS

No.	Name	Function
1	A	Anode (+)
2	C	Cathode (-)

ABSOLUTE MAXIMUM RATINGS

Beyond these values damage may occur (Ta = 25°C, unless otherwise noted)

Item No.	Symbol	Parameter	Conditions	Min.		Max.		Unit
G001	IF	Forward Current (DC)				100		mA
G002	IFSM	Surge Forward Current, iC-SN85z	tp ≤ 10 μs, 5 % duty cycle			1000		mA
G003	VR	Reverse Voltage				5		V
G004	P	Power Dissipation	temperature dependence see fig. 1			150		mW

All voltages are referenced to ground unless otherwise stated.

All currents flowing into the device pins are positive; all currents flowing out of the device pins are negative.

iC-SN85 BLCC SN2C

INFRARED LED



Rev B1, Page 2/7

THERMAL DATA

Item No.	Symbol	Parameter	Conditions	Min.	Typ.	Max.	Unit
T01	Ta	Operating Ambient Temperature Range		-40		125	°C
T02	Ts	Storage Temperature Range		-40		125	°C
T03	Tpk	Soldering Temperature	tpk < 5 s, manual soldering; Not suitable for reflow or vapor phase soldering.			260	°C
T04	Rthja	Thermal Resistance Junction to Ambient			300		K/W
T05	Tj	Junction Temperature		-40		125	°C

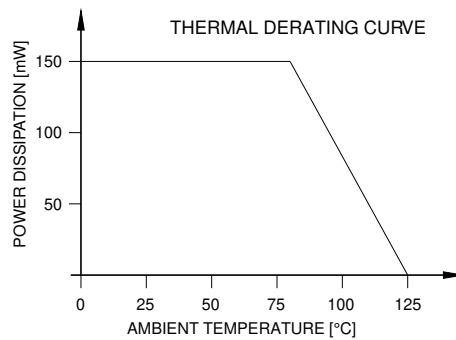

Figure 1: Maximum power dissipation with respect to temperature

ELECTRICAL CHARACTERISTICS

Tamb = 25°C, unless otherwise noted

Item No.	Symbol	Parameter	Conditions	Min.	Typ.	Max.	Unit
Electrical and Optical Characteristics							
001	V _F	Forward Voltage	IF = 20 mA		1.4	1.8	V
002	V _R	Reverse Voltage	IR = 5 μA	5			V
003	Φ _e	Radiant Power iC-SN85z	IF = 20 mA	3.4	8.1		mW
004	TK(Φ _e)	Temperature Coefficient of Radiant Power	IF = 20 mA, Tj = 25°C...125°C		-0.6		%/K
005	λ _p	Peak Wavelength	IF = 20 mA	840	850	860	nm
006	Δλ	Spectral Half Width	IF = 20 mA		30		nm
007	2φ	Divergence	IF = 20 mA		4		deg.
008	tr, tf	Switching Time	IF = 100 mA, RL = 50 Ω		12		ns

Remarks: Measured optical characteristics may depend on conditions and equipment and thus differ in its given typical values.

RADIATION PATTERN

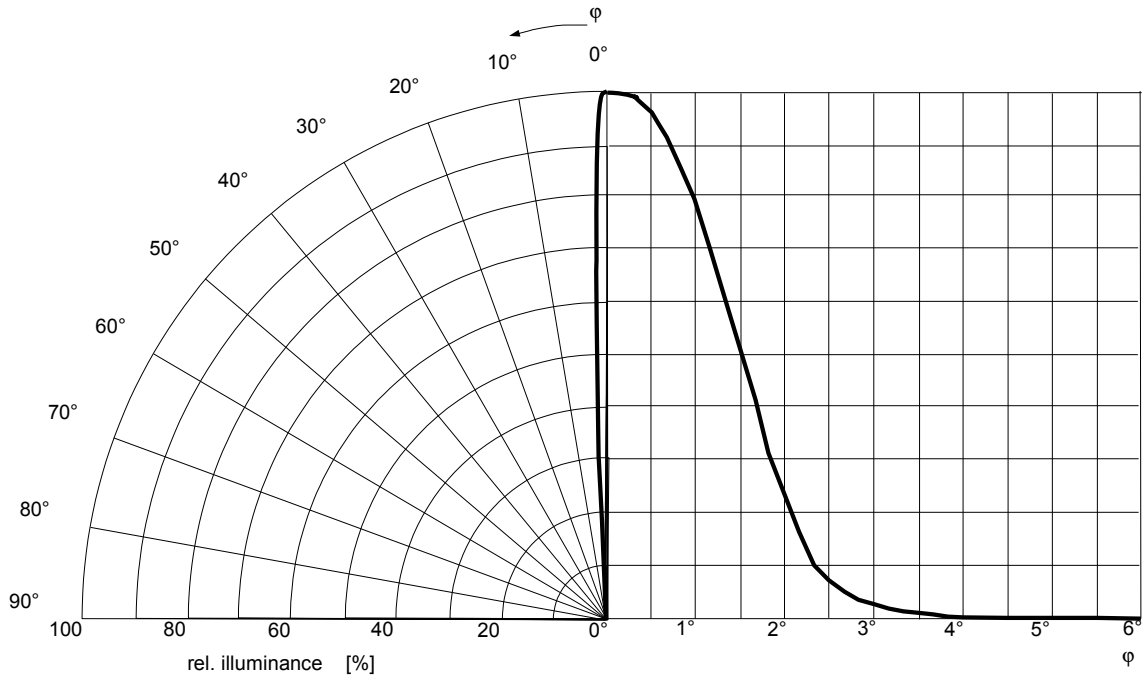

Figure 2: Rel. radiant output

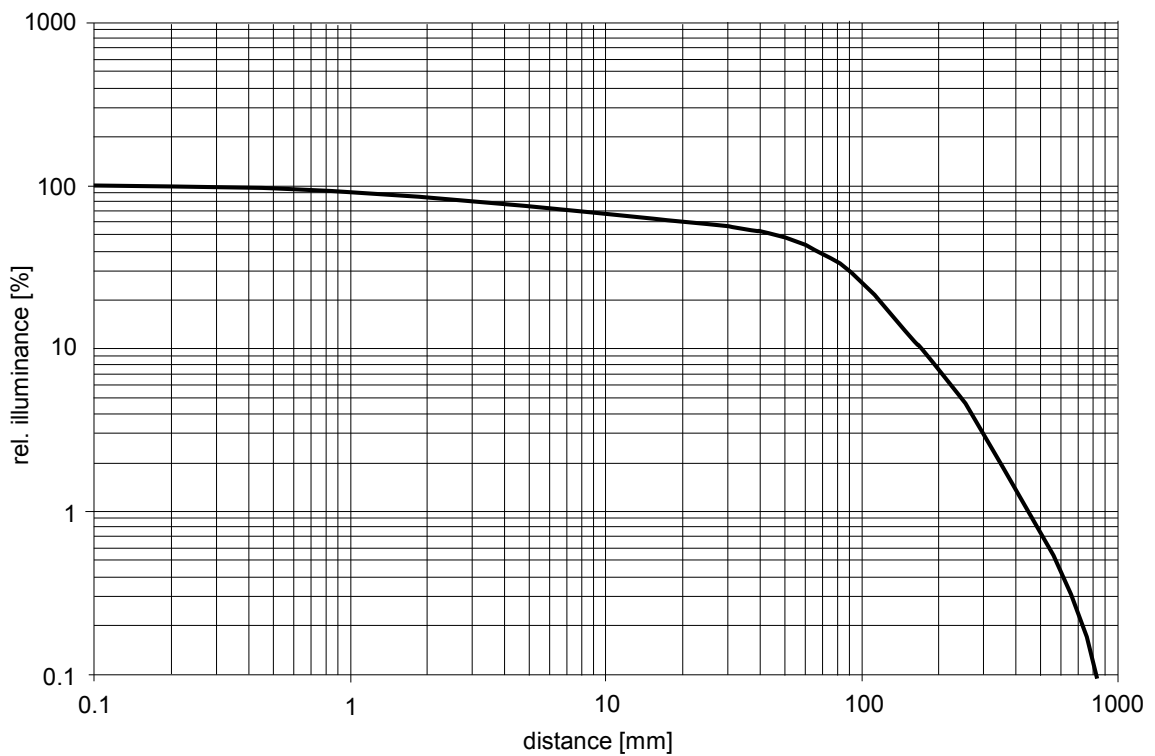
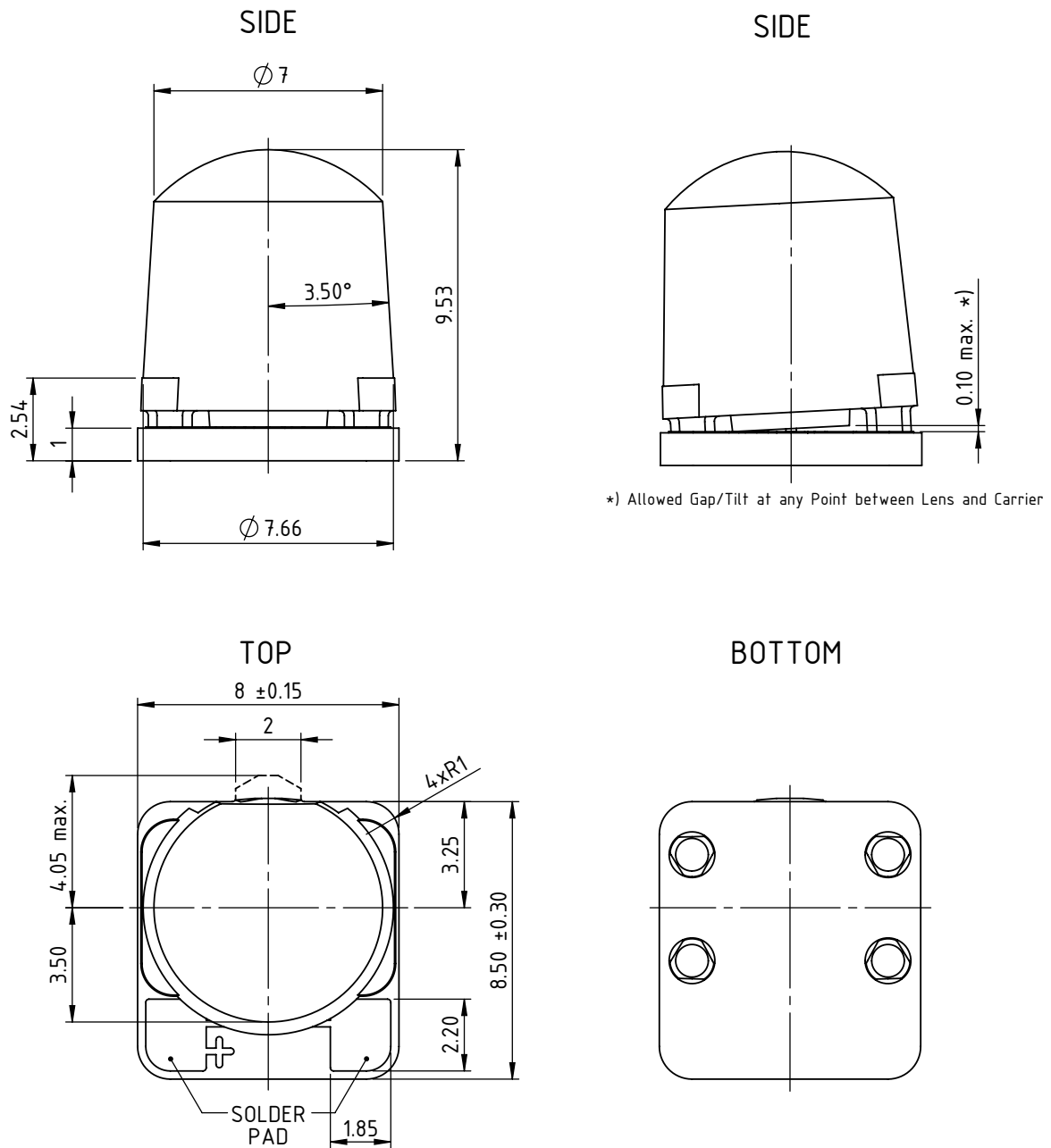

Figure 3: Rel. radiant illuminance vs. distance

PHYSICAL DIMENSIONS



drd_sn2c1_pack_1, 5:1

Figure 4: Package dimensions [mm]

SAFETY ADVICES

Depending on the mode of operation, these devices emit highly concentrated non visible infrared light which can be hazardous to the human eye.

Products which incorporate these devices have to follow the safety precautions given in IEC 60825-1 and IEC 62471.

HANDLING ADVICES

Because of the specific housing materials and geometries used, these LED devices are sensitive to rough handling or assembly and can thus be easily damaged

or may fail in regard to their electro-optical operation. Excessive mechanical stress or load on the lens surface or to the glued cap must be avoided.

DESIGN REVIEW: Notes on chip characteristics

iC-SN85 Z			
No.	Chip Design	Function, Parameter/Code	Description and Application Hints
1	iC-SN85z	initial chip release	

Table 1: Notes on chip characteristics regarding iC-SN85 Z

REVISION HISTORY

Rel.	Rel. Date *	Chapter	Modification	Page
A1	2012-12-11		Initial	all

Rel.	Rel. Date *	Chapter	Modification	Page
A2	2013-06-06	SAFETY ADVICES		5

Rel.	Rel. Date *	Chapter	Modification	Page
A3	2013-12-15	PACKAGE DIMENSIONS	PCB outline changed	4

Rel.	Rel. Date *	Chapter	Modification	Page
B1	2021-12-15	PACKAGES	Drawing update	1
		PACKAGING INFORMATION	Drawing update	1
		PHYSICAL DIMENSIONS	New lens dimension, mold incline changed	4
		HANDLING ADVICES	new	5

* Release Date format: YYYY-MM-DD

iC-SN85 BLCC SN2C

INFRARED LED



Rev B1, Page 6/7

iC-Haus expressly reserves the right to change its products, specifications and related supplements (together the Documents). A Datasheet Update Notification (DUN) gives details as to any amendments and additions made to the relevant Documents on our internet website www.ichaus.com/DUN and is automatically generated and shall be sent to registered users by email.
Copying – even as an excerpt – is only permitted with iC-Haus' approval in writing and precise reference to source.

The data and predicted functionality is intended solely for the purpose of product description and shall represent the usual quality and behaviour of the product. In case the Documents contain obvious mistakes e.g. in writing or calculation, iC-Haus reserves the right to correct the Documents and no liability arises insofar that the Documents were from a third party view obviously not reliable. There shall be no claims based on defects as to quality and behaviour in cases of insignificant deviations from the Documents or in case of only minor impairment of usability.
No representations or warranties, either expressed or implied, of merchantability, fitness for a particular purpose or of any other nature are made hereunder with respect to information/specification resp. Documents or the products to which information refers and no guarantee with respect to compliance to the intended use is given. In particular, this also applies to the stated possible applications or areas of applications of the product.

iC-Haus products are not designed for and must not be used in connection with any applications where the failure of such products would reasonably be expected to result in significant personal injury or death (*Safety-Critical Applications*) without iC-Haus' specific written consent. Safety-Critical Applications include, without limitation, life support devices and systems. iC-Haus products are not designed nor intended for use in military or aerospace applications or environments or in automotive applications unless specifically designated for such use by iC-Haus.
iC-Haus conveys no patent, copyright, mask work right or other trade mark right to this product. iC-Haus assumes no liability for any patent and/or other trade mark rights of a third party resulting from processing or handling of the product and/or any other use of the product.

Software and its documentation is provided by iC-Haus GmbH or contributors "AS IS" and is subject to the ZVEI General Conditions for the Supply of Products and Services with iC-Haus amendments and the ZVEI Software clause with iC-Haus amendments (www.ichaus.com/EULA).

iC-SN85 BLCC SN2C

INFRARED LED



Rev B1, Page 7/7

ORDERING INFORMATION

Type	Package	Order Designation
iC-SN85	2-Pin BLCC, 8 mm x 8.5 mm, height 9.53 mm RoHS compliant	iC-SN85 BLCC SN2C

Please send your purchase orders to our order handling team:

Fax: +49 (0) 61 35 - 92 92 - 692

E-Mail: dispo@ichaus.com

For technical support, information about prices and terms of delivery please contact:

iC-Haus GmbH
Am Kuemmerling 18
D-55294 Bodenheim
GERMANY

Tel.: +49 (0) 61 35 - 92 92 - 0
Fax: +49 (0) 61 35 - 92 92 - 192
Web: <http://www.ichaus.com>
E-Mail: sales@ichaus.com

Appointed local distributors: http://www.ichaus.com/sales_partners