

iC-MSC SIN/COS SIGNAL CONDITIONER WITH FAIL-SAFE 1 Vpp LINE DRIVER

preliminary



Rev A2, Page 1/35

FEATURES

- ◆ PGA inputs for differential or single-ended signals up to 500 kHz
- ◆ Unity gain capable for high output sensors
- ◆ Selectable adaptation to voltage or current signals
- ◆ Flexible pin assignment due to signal path multiplexers
- ◆ Sine/Cosine signal conditioning for offset, amplitude and phase
- ◆ Separate index signal conditioning
- ◆ Short-circuit-proof and reverse polarity tolerant output drivers (1 Vpp to 100 Ω)
- ◆ Output signal stabilization by advanced sensor control with adjustable deadband
- ◆ Signal and system monitoring with configurable alarm output
- ◆ Supply voltage monitoring with integrated switches for reversed-polarity-safe systems
- ◆ Excessive temperature protection with sensor calibration
- ◆ I²C multi-master interface for in-circuit calibration
- ◆ Supply from 4.3 to 5.5 V, operation within -40 to +125 °C
- ◆ Verifiable chip release code
- ◆ Pin-compatible interpolation ICs available (iC-MQ, iC-PI etc.)

APPLICATIONS

- ◆ Programmable sensor interface for optical and magnetic position sensors
- ◆ Linear gauges and incremental encoders
- ◆ Linear scales

PACKAGES



TSSOP20-TP
RoHS compliant

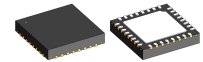

QFN32
5 mm x 5 mm x 0.9 mm
RoHS compliant
(PRELIMINARY)

BLOCK DIAGRAM

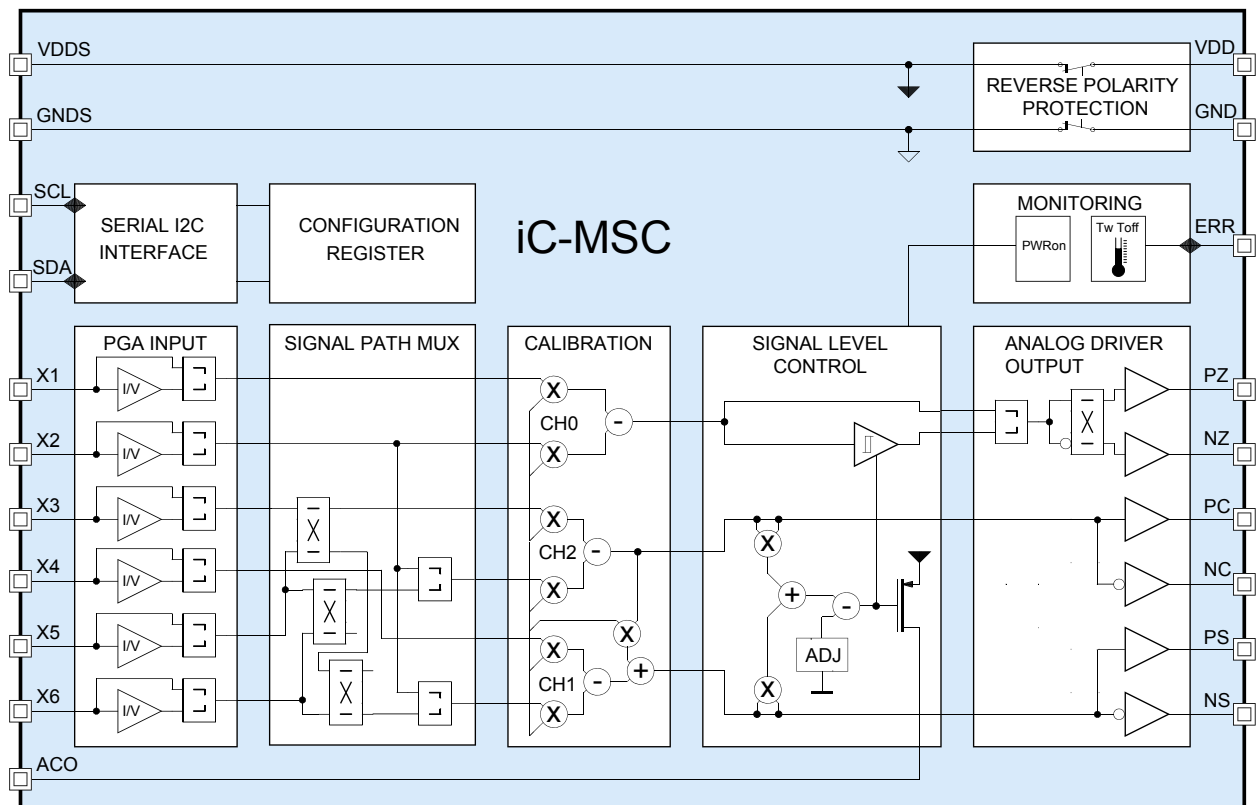

DESCRIPTION

iC-MSC is a signal conditioner with line drivers for sine/cosine sensors which are used to determine positions in linear and angular encoders, for example.

Programmable instrumentation amplifiers with selectable gain levels allow differential or single-ended, referenced input signals; an external reference voltage can be connected to input X2 then operated as a reference input.

The modes of operation differentiate between high impedance (V-Modes) and low impedance (I-Modes). This adaptation of the iC to voltage or current signals enables MR sensor bridges or photosensors to be directly connected to the device.

The integrated signal conditioning unit allows signal amplitudes and offset voltages to be calibrated accurately and any phase error between the sine and cosine signals to be corrected. The channel for the index signal can be configured separately. The index signal is then output either as an analog or a differential square-wave signal (with low/high levels analogous to the sine/cosine amplitude).

A control signal is generated from the conditioned signals which can track the transmitting LED of optical encoders via the integrated 50 mA driver stage (output ACO). If MR sensors are connected this driver stage can also track the power supply of the measuring bridges.

By tracking the sensor's energy supply any temperature and aging effects are compensated for, the input signals stabilized and the exact calibration of the input signals is maintained. This enables a constantly accurate signal for the subsequent device, a PLC or

motion controller, across the entire operating temperature range.

If control limits are reached, these can be indicated at the maskable error pin ERR. Faults such as signal loss due to wire breakage, short circuiting, dirt or aging, for example, can be detected and indicated.

iC-MSC includes system diagnosis functions which check whether the sensor is working properly or not. For all error events the user can select whether the fault is indicated at the pin ERR or whether the outputs should shutdown. At the same time errors can be stored in the EEPROM to enable failures to be diagnosed at a later stage. For encoder applications the sensor signal regarding signal level and the operating temperature can be monitored, for example, the latter using an adjustable on-chip sensor.

Display error pin ERR is bidirectional; a system fault recognized externally could also be used to shutdown the outputs.

iC-MSC is protected against reverse polarity and offers its monitored supply voltage to the external circuit, thus extending the protection to the system (for load currents up to 20 mA). Reverse polarity protection also covers the short-circuit-proof output drivers so that an unintentional faulty wiring during initial operation is tolerated.

On being activated the device configuration is loaded via the serial I²C interface from an external EEPROM and verified with a CRC. A microcontroller can also configure iC-MSC; the implemented interface is multimaster-capable and allows direct RAM access to configuration data.

CONTENTS

PACKAGING INFORMATION	4	Current Signals	22
PIN CONFIGURATION TSSOP20-TP	4	Input Reference Voltages	22
PACKAGE DIMENSIONS : TSSOP20-TP	5	Input Clamping Resistors	23
PIN CONFIGURATION QFN32-5x5		Examples of Permissible Input Voltages	23
- PRELIMINARY -	6		
PACKAGE DIMENSIONS : QFN32-5x5		SIGNAL PATH MULTIPLEXING	25
(5 mm x 5 mm)	7		
ABSOLUTE MAXIMUM RATINGS	8	SIGNAL CONDITIONING CH1, CH2	26
THERMAL DATA	8	Gain Settings	26
ELECTRICAL CHARACTERISTICS	9	Offset Calibration	27
PROGRAMMING	14	Phase Correction CH1 to CH2	27
REGISTER MAP	15	SIGNAL CONDITIONING CH0	28
SERIAL I²C INTERFACE	17	Gain Settings CH0	28
EEPROM Selection	17	Offset Calibration CH0	28
Device Startup	17	SIGNAL LEVEL CONTROL and SIGNAL	29
Configuration Data Checksum	17	MONITORING	29
I ² C Slave Mode (ENSL = 1)	18	Deadband Control	29
BIAS CURRENT SOURCE AND		Square Control Mode	29
TEMPERATURE SENSOR	19	Sum Control Mode	30
Bias Current Calibration	19	Constant Current Source	30
Temperature Sensor Calibration	19	ERROR MONITORING AND ALARM OUTPUT	31
OPERATING MODES	20	Alarm Output: I/O pin ERR	31
Calibration Op. Modes	20	Excessive Temperature Warning	31
Special Device Test Functions	20	Driver Shutdown	31
Signal Filter	20	Error Protocol	32
TEST MODE	21	REVERSE POLARITY PROTECTION	32
PGA INPUT CONFIGURATION	22	APPLICATION HINTS	33
Voltage Signals	22	Connecting MR sensor bridges for	
		safety-related applications	33
		PLC Operation	33
		REVISION HISTORY	34

iC-MSC SIN/COS SIGNAL CONDITIONER WITH FAIL-SAFE 1 V_{pp} LINE DRIVER

preliminary



Rev A2, Page 4/35

PACKAGING INFORMATION

PIN CONFIGURATION TSSOP20-TP

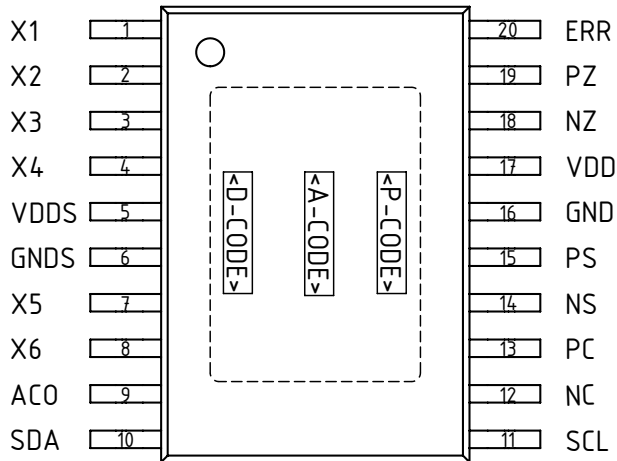

PIN FUNCTIONS

No.	Name	Function
1	X1	Signal Input 1 (Index +)
2	X2	Signal Input 2 (Index -)
3	X3	Signal Input 3
4	X4	Signal Input 4
5	VDDS ¹	Switched Supply Output and Internal Analog Supply Voltage (reverse-polarity-proof, load 20 mA max.)
6	GNDS ¹	Switched Ground (reverse-polarity-proof)
7	X5	Signal Input 5
8	X6	Signal Input 6
9	ACO	Signal Level Control, high-side current source output
10	SDA	Serial Configuration Interface, data line
11	SCL	Serial Configuration Interface, clock line
12	NC	Neg. Cosine Output
13	PC	Pos. Cosine Output
14	NS	Neg. Sine Output
15	PS	Pos. Sine Output
16	GND	Ground
17	VDD	+4.5 to +5.5 V Supply Voltage
18	NZ	Neg. Index Output
19	PZ	Pos. Index Output
20	ERR	Error Signal (In/Out), and Test Mode Trigger Input
	TP ²	Thermal Pad (TSSOP20-TP)

IC top marking: <P-CODE> = product code, <A-CODE> = assembly code (subject to changes), <D-CODE> = date code (subject to changes);

¹ It is advisable to connect a bypass capacitor of about 100 nF (up to 1 μ F max.) close to the chip's analog supply terminals.

² To improve heat dissipation the *thermal pad* of the package (bottom side) should be joined to an extended copper area which must have GNDS potential.

iC-MSC SIN/COS SIGNAL CONDITIONER WITH FAIL-SAFE 1 Vpp LINE DRIVER

preliminary



Rev A2, Page 5/35

PACKAGE DIMENSIONS : TSSOP20-TP

SIDE

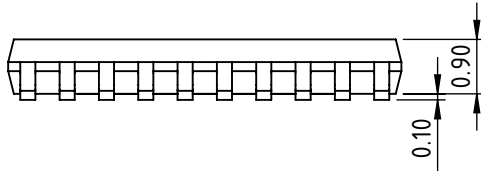

FRONT

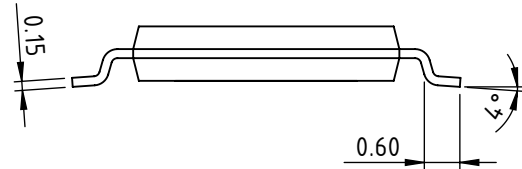

TOP

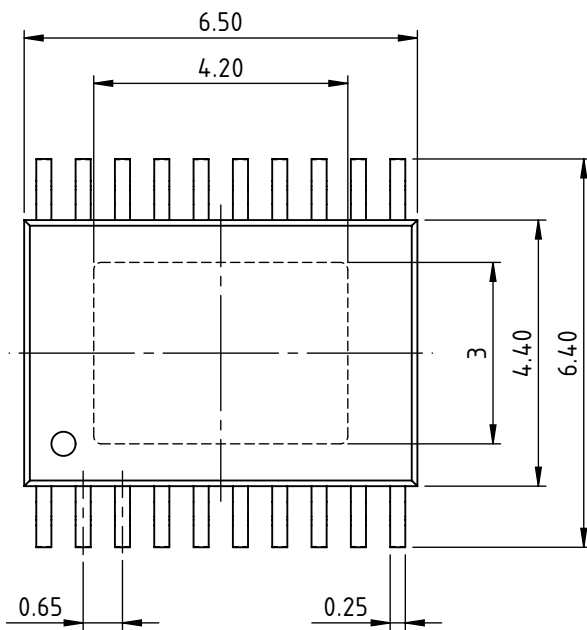

RECOMMENDED PCB-FOOTPRINT

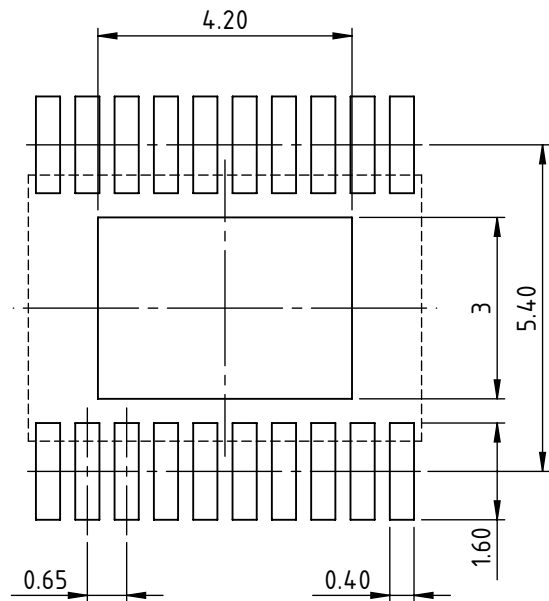

All dimensions given in mm.
Tolerances of form and position according to JEDEC MO-153

dra_tssop20-tp-1_pack_1, 8:1

iC-MSC SIN/COS SIGNAL CONDITIONER WITH FAIL-SAFE 1 V_{pp} LINE DRIVER

preliminary



Rev A2, Page 6/35

PIN CONFIGURATION QFN32-5x5 - PRELIMINARY -

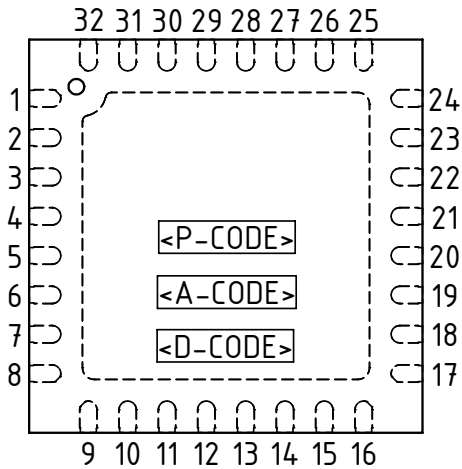

PIN FUNCTIONS

No.	Name	Function
1, 2	n.c. ³	
3	ERR	Error Signal (In/Out), and Test Mode Trigger Input
4, 5	n.c. ³	
6	X1	Signal Input 1 (Index +)
7	X2	Signal Input 2 (Index -)
8, 9	n.c. ³	
10	X3	Signal Input 3
11	X4	Signal Input 4
12	VDDS ¹	Switched Supply Output and Internal Analog Supply Voltage (reverse-polarity-proof, load 20 mA max.)
13	GNDS ¹	Switched Ground (reverse-polarity-proof)
14	X5	Signal Input 5
15	X6	Signal Input 6
16	n.c. ³	
17	ACO	Signal Level Control, high-side current source output
18	n.c. ³	
19	SDA	Serial Configuration Interface, data line
20, 21	n.c. ³	
22	SCL	Serial Configuration Interface, clock line
23, 24	n.c. ³	
25	NC	Neg. Cosine Output
26	PC	Pos. Cosine Output
27	NS	Neg. Sine Output
28	PS	Pos. Sine Output
29	GND	Ground
30	VDD	+4.5 to +5.5 V Supply Voltage
31	NZ	Neg. Index Output
32	PZ	Pos. Index Output
	BP ²	Backside Paddle

(top view) IC top marking: <P-CODE> = product code, <A-CODE> = assembly code (subject to changes), <D-CODE> = date code (subject to changes);

¹ It is advisable to connect a bypass capacitor of about 100 nF (up to 1 μF max.) close to the chip's analog supply terminals.

² To improve heat dissipation the backside paddle should be soldered and joined to an extended copper area, which must have GNDS potential.

³ Pin numbers marked n.c. are not connected.

iC-MSC SIN/COS SIGNAL CONDITIONER WITH FAIL-SAFE 1 Vpp LINE DRIVER

preliminary



Rev A2, Page 7/35

PACKAGE DIMENSIONS : QFN32-5x5 (5 mm x 5 mm)

RECOMMENDED PCB-FOOTPRINT

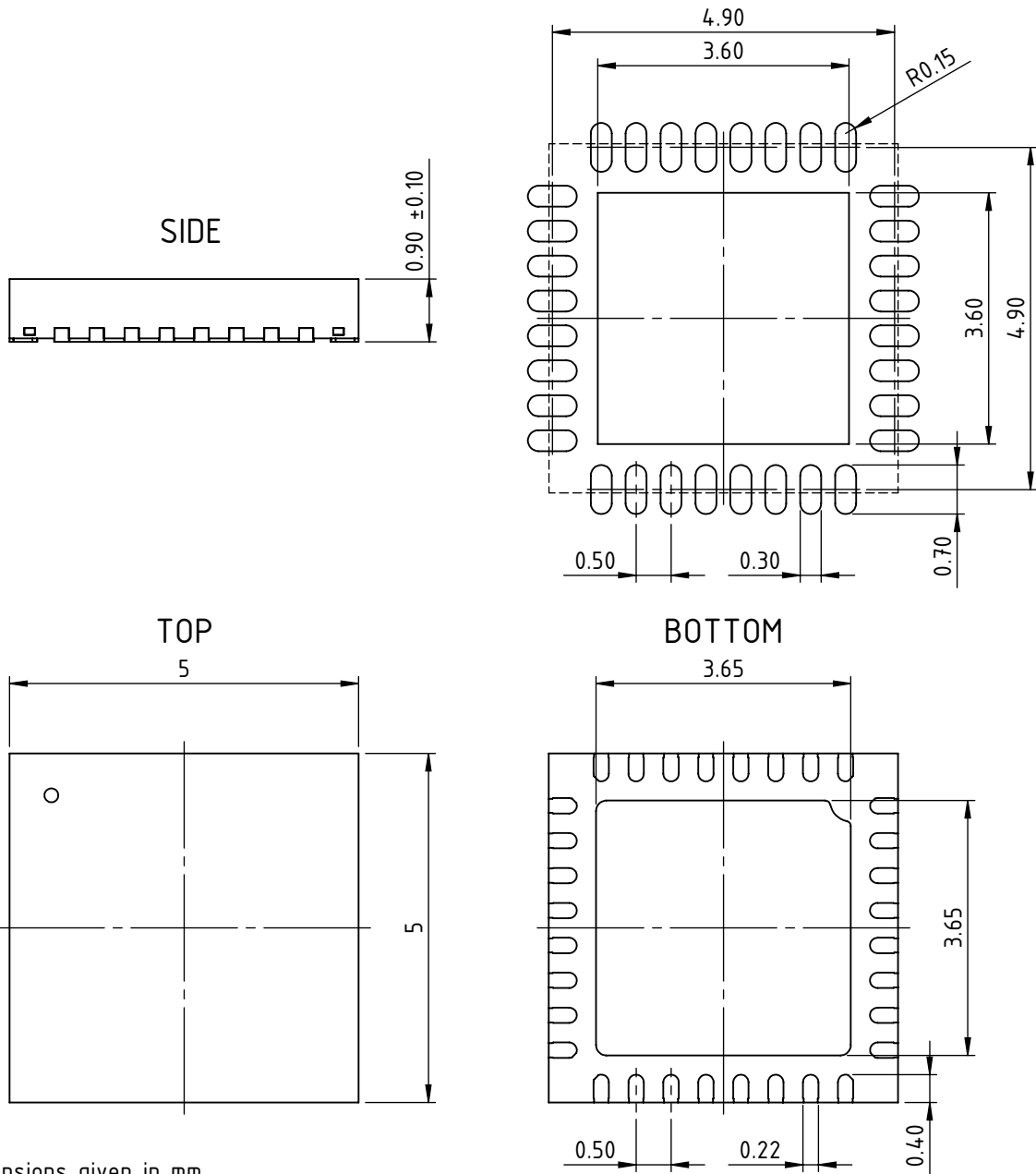

All dimensions given in mm.
Tolerances of form and position according to JEDEC MO-220.

drb_qfn32-5x5-6_pack_1, 10:1

iC-MSC SIN/COS SIGNAL CONDITIONER WITH FAIL-SAFE 1 Vpp LINE DRIVER

preliminary



Rev A2, Page 8/35

ABSOLUTE MAXIMUM RATINGS

These ratings do not imply operating conditions; functional operation is not guaranteed. Beyond these ratings device damage may occur.

Item No.	Symbol	Parameter	Conditions	Limits		Unit
				Min.	Max.	
G001	V()	Voltage at VDD, PC, NC, PS, NS, PZ, NZ, ACO	relative to GND	-6	6	V
G002	V()	Voltage at ERR	relative to GND	-6	8	V
G003	V()	Pin-To-Pin Voltage between VDD, GND, PC, NC, PS, NS, PZ, NZ, ACO, ERR			6	V
G004	V()	Voltage at VDDS	no reversed polarity at VDD and GND		VDD	V
G005	V()	Voltage at GNDS relative to GND	no reversed polarity at VDD and GND	-0.3	+0.3	V
G006	V()	Voltage at X1...X6, SCL, SDA		-0.3	VDDS + 0.3	V
G007	I(VDD)	Current in VDD		-100	100	mA
G008	I()	Current in VDDS, GNDS		-50	50	mA
G009	I()	Current in X1...X6, SCL, SDA, ERR, PC, NC, PS, NS, PZ, NZ		-20	20	mA
G010	I(ACO)	Current in ACO		-100	20	mA
G011	Vd()	ESD Susceptibility at all pins	HBM 100 pF discharged through 1.5 kΩ		2	kV
G012	Ptot	Permissible Power Dissipation	TSSOP20-TP, QFN32-5x5		400	mW
G013	Tj	Junction Temperature		-40	150	°C
G014	Ts	Storage Temperature Range		-40	150	°C
G015	V()	Voltage at VDDS	no reversed polarity at VDD and GND		VDD	V

THERMAL DATA

VDD = 4.3...5.5 V

Item No.	Symbol	Parameter	Conditions	Limits			Unit
				Min.	Typ.	Max.	
T01	Ta	Operating Ambient Temperature Range	iC-MSC TSSOP20-TP	-40		125	°C
			iC-MSC QFN32-5x5	-40		125	°C
T02	Rthja	Thermal Resistance Chip to Ambient	TSSOP20-TP surface mounted to PCB (incl. the thermal pad), according to JEDEC 51		35		K/W
T03	Rthja	Thermal Resistance Chip to Ambient	QFN32-5x5 surface mounted to PCB (incl. the backside paddle), according to JEDEC 51		40		K/W

All voltages are referenced to Pin GNDS unless otherwise stated.

All currents flowing into the device pins are positive; all currents flowing out of the device pins are negative.

iC-MSC SIN/COS SIGNAL CONDITIONER WITH FAIL-SAFE 1 Vpp LINE DRIVER

preliminary



Rev A2, Page 9/35

ELECTRICAL CHARACTERISTICS

Operating conditions: VDD = 4.3...5.5 V, Tj = -40...140 °C, IBN calibrated to 200 µA, reference point GNDS, unless otherwise stated.

Item No.	Symbol	Parameter	Conditions				Unit
				Min.	Typ.	Max.	
Total Device							
001	VDD	Permissible Supply Voltage VDD versus GND	Load current I(VDDS) < -10 mA	4.3 4.5		5.5 5.5	V V
002	I(VDD)	Supply Current in VDD to GND	Tj = 27 °C, no load		25	50	mA
003	I(VDDS)	Permissible Load Current VDDS		-20		0	mA
004	Vc()hi	Clamp Voltage hi at all pins				11	V
005	Vc()hi	Clamp Voltage hi at inputs SCL, SDA	Vc()hi = V() – V(VDDS), I() = 1 mA	0.4		1.5	V
006	Vc()hi	Clamp Voltage hi at inputs X1...X6	Vc()hi = V() – V(VDDS), I() = 4 mA	0.3		1.2	V
007	Vc()lo	Clamp Voltage lo at all pins	I() = -4 mA	-1.2		-0.3	V
008	Irev(VDD)	Reverse-Polarity Current VDD vs. GND	V(VDD) = -5.5 V...-4.3 V	-1		1	mA
Signal Conditioning, PGA Inputs X3...X6							
101	Vin()sig	Permissible V-Mode Input Voltage Range	RIN12(3:0) = 0x01 (V-Mode 1:1) BIAS12 = 1, RIN12(3:0) = 0x09 (V-Mode 4:1) BIAS12 = 0, RIN12(3:0) = 0x09 (V-Mode 4:1)	0.75 0 0		VDDS - 1.5 VDDS VDDS - 1.5	V V V
102	Vin()diff	Recommended Differential V-Mode Input Voltage	Vin()diff = V(PCHx) – V(NCHx); RIN12(3:0) = 0 (V-Mode 1:1) RIN12(3:0) = 1 (V-Mode 4:1)	10 40		1500 6000	mVpp mVpp
103	Vin()os	V-Mode Input Offset Voltage	referred to side of input, MODE(3:0) = 0x0 (normal), RIN12(3:0) = 0x01 (V-Mode 1:1); Max. gain: GR12, GF1, GF2 = max.	-500		+500	µV
105	Iin()	V-Mode Input Current	RIN12(3:0) = 0x01 (V-Mode 1:1)	-10		10	µA
106	Iin()sig	Permissible I-Mode Input Current Range	BIAS12 = 1, RIN12(0) = 0 BIAS12 = 0, RIN12(0) = 0	10 -300		300 -10	µA µA
107	Rin()	I-Mode / V-Mode Input Resistance	referenced to VREFin, Tj = 27 °C; RIN12(3:0) = 0x00 RIN12(3:0) = 0x02 RIN12(3:0) = 0x04 RIN12(3:0) = 0x06 RIN12(3:0) = 0x09 (V-Mode 4:1)	1.1 1.6 2.2 3.2 16	1.7 2.5 3.5 4.9 20	2.1 3.0 4.2 6.0 24	kΩ kΩ kΩ kΩ kΩ
108	R2()	I-Mode Conversion Resistor	referenced to VREFin, Tj = 27 °C; RIN12(3:0) = 0x00 RIN12(3:0) = 0x02 RIN12(3:0) = 0x04 RIN12(3:0) = 0x06 RIN12(3:0) = 0x09 (V-Mode 4:1)		1.6 2.3 3.2 4.6 5.0		kΩ kΩ kΩ kΩ kΩ
109	TCRin()	Temperature Coefficient Rin			0.15		%/K
110	VREFI()	Internal Reference Voltage VREFI ₁₂	BIAS12 = 1, RIN12(0) = 0 BIAS12 = 0, RIN12(0) = 0	1.35 2.25	1.5 2.5	1.65 2.75	V V
111	G12	Selectable Gain Factors	RIN12(3:0) = 0x01, GR12, GF1, GF2 = 0x0 RIN12(3:0) = 0x01, GR12, GF1, GF2 = max. RIN12(3:0) = 0x09, GR12, GF1, GF2 = 0x0 RIN12(3:0) = 0x09, GR12, GF1, GF2 = max.		0.667 100		
112	ΔGdiff	Differential Gain Accuracy	calibration range 11 bit	-0.5		0.5	LSB
113	ΔGabs	Absolute Gain Accuracy	calibration range 11 bit, guaranteed monotony	-1		1	LSB
114	VOScal	Offset Calibration Range	referenced to the selected source (VOS12); ORx = 00 ORx = 01 ORx = 10 ORx = 11		±100 ±200 ±600 ±1200		%V() %V() %V() %V()
115	ΔVOSdiff	Differential Linearity Error of Offset Correction	calibration range 11 bit	-0.5		0.5	LSB

iC-MSC SIN/COS SIGNAL CONDITIONER WITH FAIL-SAFE 1 V_{pp} LINE DRIVER

preliminary



Rev A2, Page 10/35

ELECTRICAL CHARACTERISTICS

Operating conditions: VDD = 4.3...5.5 V, T_j = -40...140 °C, IBN calibrated to 200 μA, reference point GNDS, unless otherwise stated.

Item No.	Symbol	Parameter	Conditions	Min.	Typ.	Max.	Unit
116	ΔVOSint	Integral Linearity Error of Offset Correction	calibration range 11 bit	-1		1	LSB
117	PHIkorr	Phase Error Calibration Range	CH1 versus CH2		±10.4		°
118	ΔPHIdiff	Differential Linearity Error of Phase Calibration	calibration range 10 bit	-0.5		0.5	LSB
119	ΔPHLint	Integral Linearity Error of Phase Calibration	calibration range 10 bit	-1		1	LSB
120	fin(max)	Permissible Input Frequency		500			kHz
121	fc(in)	Input Amplifier Cut-off Frequency (-3dB)		250			kHz
Signal Conditioning, PGA Inputs X1, X2							
201	Vin(sig)	Permissible V-Mode Input Voltage Range	RIN0(3:0) = 0x01 (V-Mode 1:1) BIAS0 = 1, RIN0(3:0) = 0x09 (V-Mode 4:1) BIAS0 = 0, RIN0(3:0) = 0x09 (V-Mode 4:1)	0.75 0 0		VDDS - 1.5 VDDS VDDS - 1.5	V V V
202	Vin(diff)	Recommended Differential V-Mode Input Voltage	Vin(diff) = V(PCH0) - V(NCH0); RIN0(3:0) = 0x01 (V-Mode 1:1) RIN0(3:0) = 0x09 (V-Mode 4:1)	10 40		1500 6000	mV _{pp} mV _{pp}
203	Vin(os)	V-Mode Input Offset Voltage	referred to side of input, MODE(3:0) = 0x0 (normal), RIN0(3:0) = 0x01 (V-Mode 1:1); Max. gain: GR0, GF0 = max.	-500		+500	μV
205	Iin()	V-Mode Input Current	RIN0(3:0) = 0x01 (V-Mode 1:1)	-10		10	μA
206	Iin(sig)	Permissible I-Mode Input Current Range	BIAS0 = 1, RIN0(0) = 0 BIAS0 = 0, RIN0(0) = 0	10 -300		300 -10	μA μA
207	Vout(X2)	Output Voltage at X2	BIASEX = 10, referenced to VREFin12; I(X2) = -10...+10 μA I(X2) = -150...+150 μA	95 90	100	105 110	% %
208	Vin(X2)	Permissible Input Voltage VREF _{ex} at X2	BIASEX = 11	0.5		VDDS - 2	V
209	Rin(X2)	Input Resistance at X2	BIASEX = 11, RIN0(3:0) = 0x01, RIN12(3:0) = 0x01 (all channels in V-Mode 1:1)	20	27	35	kΩ
210	Rin()	I-Mode / V-Mode Input Resistance	referenced to VREFin, T _j = 27 °C; RIN0(3:0) = 0x00 RIN0(3:0) = 0x02 RIN0(3:0) = 0x04 RIN0(3:0) = 0x06 RIN0(3:0) = 0x09 (V-Mode 4:1)	1.1 1.6 2.2 3.2 16	1.6 2.3 3.2 4.6 20	2.1 3.0 4.2 6.0 24	kΩ kΩ kΩ kΩ kΩ
211	R2()	I-Mode Conversion Resistor	referenced to VREFin, T _j = 27 °C; RIN0(3:0) = 0x00 RIN0(3:0) = 0x02 RIN0(3:0) = 0x04 RIN0(3:0) = 0x06 RIN0(3:0) = 0x09 (V-Mode 4:1)		1.6 2.3 3.2 4.6 5.0		kΩ kΩ kΩ kΩ kΩ
212	TCRin()	Temperature Coefficient Rin			0.15		%/K
213	VREFI()	Internal Reference Voltage VREFI ₀	BIAS0 = 1, RIN0(0) = 0 BIAS0 = 0, RIN0(0) = 0	1.35 2.25	1.5 2.5	1.65 2.75	V V
214	G0	Selectable Gain Factors	RIN0(3:0) = 0x01, GR0 and GF0 = 0x0 RIN0(3:0) = 0x01, GR0 and GF0 = max. RIN0(3:0) = 0x09, GR0 and GF0 = 0x0 RIN0(3:0) = 0x09, GR0 and GF0 = max		0.667 100 0.167 25		
215	ΔGdiff	Differential Gain Accuracy	calibration range 5 bit	-0.5		0.5	LSB
216	ΔGabs	Absolute Gain Accuracy	calibration range 5 bit, guaranteed monotony	-1		1	LSB
217	VOScal	Offset Calibration Range	referenced to the selected source (REFVOS); OR0 = 00 OR0 = 01 OR0 = 10 OR0 = 11		±100 ±200 ±600 ±1200		%V() %V() %V() %V()

iC-MSC SIN/COS SIGNAL CONDITIONER WITH FAIL-SAFE 1 V_{pp} LINE DRIVER

preliminary



Rev A2, Page 11/35

ELECTRICAL CHARACTERISTICS

Operating conditions: VDD = 4.3...5.5 V, T_j = -40...140 °C, IBN calibrated to 200 μA, reference point GNDS, unless otherwise stated.

Item No.	Symbol	Parameter	Conditions	Min.	Typ.	Max.	Unit
218	ΔVOSdiff	Differential Linearity Error of Offset Correction	calibration range 6 bit	-0.5		0.5	LSB
219	ΔVOSint	Integral Linearity Error of Offset Correction	calibration range 6 bit	-1		1	LSB
Signal Filter							
301	fc	Cut-off Frequency	ENF = 1, f(in) 100 kHz for sine/cosine			4000	kHz
302	phi	Phase Delay (output vs. input)	ENF = 1, f(in) 500 kHz for sine/cosine			10	°
Index Pulse Comparator Output PZ, NZ							
401	Vpk()	Output Amplitude With Sensor Tracking via ACO	EAZ = 1, ADJ(4:0) = 0x19	225	250	275	mV
402	SR()	Output Slew Rate	EAZ = 1		1		V/μs
Line Driver Outputs PS, NS, PC, NC, PZ, NZ							
501	Vpk()max	Permissible Output Amplitude	VDD = 4.5 V, DC level = VDD/2, RL = 50 Ω vs. VDD/2			300	mV
502	Vpk()	Output Amplitude With Sensor Tracking via ACO	ADJ(8:0) = 0x19	225	250	275	mV
503	fc(out)	Cut-off Frequency	CL = 250 pF	500			kHz
504	Isc()	Short-circuit Current	pin shorten to VDD or GND	10	30	50	mA
505	I _{lk} ()	Tristate Leakage Current	tristate or reversed supply	-1		1	μA
506	Rout()	Output Impedance	BYP = 0, MODE = 0x02 (Calibration 2)		5		kΩ
507	fout(cal)	Permissible Output Frequency for Calibration	BYP = 0, MODE = 0x02 (Calib. 2), CL = 250 pF			2	kHz
508	Rout(tm)	Bypass Resistance	BYP = 1, MODE = 0x02, 0x06		7		kΩ
Signal Level Control, Current Source Output ACO							
601	Vs()hi	Saturation Voltage hi at ACO vs. VDD	Vs() = VDD - V(); ADJ(8:0) = 0x11F, I() = -5 mA ADJ(8:0) = 0x13F, I() = -10 mA ADJ(8:0) = 0x15F, I() = -25 mA ADJ(8:0) = 0x17F, I() = -50 mA			1 1 1 1.2	V V V V
602	Isc()hi	Short-circuit Current hi in ACO	V() = 0 ... VDD - Vs()hi; ADJ(8:0) = 0x11F ADJ(8:0) = 0x13F ADJ(8:0) = 0x15F ADJ(8:0) = 0x17F	-10 -20 -50 -100	-66	-5 -10 -25 -50	mA mA mA mA
603	tr()	Current Rise Time in ACO	I(ACO): 0 → 90 % setpoint, ADJMODE = 0x1		1		ms
604	tset()	Current Settling Time in ACO	Square control active, I(ACO): 50 → 100 % setpoint, ADJMODE = 0x1		400		μs
605	It()min	Control Range Monitoring 1: lower limit	referenced to range ADJ(6:5)		3		%Isc
606	It()max	Control Range Monitoring 2: upper limit	referenced to range ADJ(6:5)		90		%Isc
607	Vt()min	Signal Level Monitoring 1: lower limit	referenced to Vscq()		40		%Vpp
608	Vt()max	Signal Level Monitoring 2: upper limit	referenced to Vscq()		130		%Vpp
609	Vin(ACO)	Permissible Input Voltage for Offset-Tracking	versus GNDS, VOS12 = 0x0	0		VDDS	V
Test Current ERR							
701	I(ERR)	Permissible Test Current	test mode activated	0		1	mA

iC-MSC SIN/COS SIGNAL CONDITIONER WITH FAIL-SAFE 1 V_{pp} LINE DRIVER

preliminary



Rev A2, Page 12/35

ELECTRICAL CHARACTERISTICS

Operating conditions: VDD = 4.3...5.5 V, T_j = -40...140 °C, IBN calibrated to 200 μA, reference point GNDS, unless otherwise stated.

Item No.	Symbol	Parameter	Conditions				Unit
				Min.	Typ.	Max.	
Bias Current Source and Reference Voltages							
801	IBN()	Bias Current Source	MODE(3:0) = 0x01, I(NC) vs. VDD5	180	200	220	μA
802	VPAH	Reference Voltage VPAH	referenced to GND	45	50	55	%VDD
803	V05	Reference Voltage V05		450	500	550	mV
804	V025	Reference Voltage V025			50		%V05
Power-Down-Reset							
901	VDDon	Turn-on Threshold (power-on release)	increasing voltage at VDD vs. GND	3.7	4	4.3	V
902	VDDoff	Turn-off Threshold (power-down reset)	decreasing voltage at VDD vs. GND	3.2	3.5	3.8	V
903	VDDhys	Threshold Hysteresis	VDDhys = VDDon – VDDoff	0.3			V
Clock Oscillator							
A01	fclk()	Internal Clock Frequency	MODE(3:0) = 0x0A (measured at pin NS)	120	160	200	kHz
Error Signal Input/Output, Pin ERR							
B01	Vs() _{lo}	Saturation Voltage I _o	vs. GND, I() = 4 mA			0.4	V
B02	Isc()	Short-circuit Current I _o	vs. GND; V(ERR) ≤ VDD V(ERR) > VTMon	4 2			mA mA
B03	Vt() _{hi}	Input Threshold Voltage hi	vs. GND			2	V
B04	Vt() _{lo}	Input Threshold Voltage I _o	vs. GND	0.8			V
B05	Vt() _{hys}	Input Hysteresis	Vt() _{hys} = Vt() _{hi} – Vt() _{lo}	300	500		mV
B06	Ipu()	Input Pull-up Current	V() = 0... VDD – 1 V, EPU = 1	-400	-300	-200	μA
B07	Rpu()	Input Pull-Up Resistor	EPU = 0		500		kΩ
B08	Vpu()	Pull-up Voltage	Vpu() = VDD – V(), I() = -5 μA, EPU = 1			0.4	V
B09	VTMon	Test Mode Activation Threshold	increasing voltage at ERR			VDD + 1.5	V
B10	VTMoff	Test Mode Disabling Threshold	decreasing voltage at ERR	VDD + 0.5			V
B11	VTMhys	Test Mode Hysteresis	VTMhys = VTMon – VTMoff	0.15	0.3		V
B12	I _{lk} ()	Leakage Current	tristate or reversed supply voltage	-1	-10	-50	μA
B13	tp() _{tri}	Propagation Delay System Error to Driver Shutdown (tristate)	V(ERR): hi → I _o		35		μs
Supply Switch and Reverse Polarity Protection VDD5, GNDS							
C01	Vs()	Saturation Voltage VDD5 vs. VDD	Vs(VDD5) = VDD – V(VDD5) I(VDD5) = -10 mA...0 mA I(VDD5) = -20 mA...-10 mA			150 250	mV mV
C02	Vs()	Saturation Voltage GNDS vs. GND	Vs(GNDS) = V(GNDS) – GND I(GNDS) = 0 mA...10 mA I(GNDS) = 10 mA...20 mA			150 250	mV mV
C03	C()	Backup Capacitor Analog Supply VDD5 vs. GNDS		100			nF
Serial Configuration Interface SCL, SDA							
D01	Vs() _{lo}	Saturation Voltage I _o	I() = 4 mA			400	mV
D02	Isc()	Short-circuit Current I _o		4		80	mA
D03	Vt() _{hi}	Input Threshold Voltage hi				2	V
D04	Vt() _{lo}	Input Threshold Voltage I _o		0.8			V
D05	Vt() _{hys}	Input Hysteresis	Vt() _{hys} = Vt() _{hi} – Vt() _{lo}	300	500		mV
D06	Ipu()	Input Pull-up Current	V() = 0...VDD5 – 1 V	-650	-300	-60	μA
D07	Vpu()	Input Pull-up Voltage	Vpu() = VDD5 – V(), I() = -5 μA			0.4	V
D08	fclk(SCL)	Clock Frequency at SCL	ENFAST = 0 ENFAST = 1	60 240	80 320	100 400	kHz kHz
D09	tbusy() _{cfg}	Duration of Startup Configuration	IBN not calibrated, EEPROM access without read failure, time to outputs operational; ENFAST = 0 ENFAST = 1		40 25	55 35	ms ms

iC-MSC SIN/COS SIGNAL CONDITIONER WITH FAIL-SAFE 1 V_{pp} LINE DRIVER

preliminary



Rev A2, Page 13/35

ELECTRICAL CHARACTERISTICS

Operating conditions: VDD = 4.3...5.5 V, T_j = -40...140 °C, IBN calibrated to 200 μA, reference point GNDS, unless otherwise stated.

Item No.	Symbol	Parameter	Conditions	Min.	Typ.	Max.	Unit
D10	tbusy(jerr)	End Of I2C Communication; Time Until I2C Slave Is Enabled	IBN not calibrated; V(SDA) = 0 V V(SCL) = 0 V or arbitration lost no EEPROM CRC ERROR		4 indef. 45 95	12 135 285	ms ms ms ms
D11	td()	Start Of Master Activity On I2C Protocol Error	SCL without clock signal: V(SCL) = constant; IBN not calibrated IBN calibrated to 200 μA	25 64	80 80	240 120	μs μs
D12	td()i2c	Delay for I2C-Slave-Mode Enable	no EEPROM, V(SDA) = 0 V		4	6.2	ms
Temperature Monitoring							
E01	VTs	Temperature Sensor Voltage	VTs() = VDD5 – V(PS), T _j = 27 °C, Calibration Mode 3, no load	600	650	700	mV
E02	TCs	Temp. Co. of Temperature Sensor Voltage			-1.8		mV/K
E03	VTth	Temperature Warning Activation Threshold	VTth() = VDD5 – V(NS), T _j = 27 °C, Calibration Mode 3, no load; CFGTA(3:0) = 0x00 CFGTA(3:0) = 0x0F	260 470	310 550	360 630	mV mV
E04	TCth	Temp. Co. Temperature Warning Activation Threshold			0.06		%/K
E05	Thys	Temperature Warning Hysteresis	T _j = 27 °C	4	12	20	°C
E06	ΔT	Relative Shutdown Temperature	ΔT = T _{off} – T _w , T _j = 27 °C	4	12	20	°C

PROGRAMMING

Register Map	Page 15	Signal Conditioning CH1, CH2 (X3...X6) ..	Page 26
		GR12:	Coarse Gain Factor CH1, CH2
		GF1:	Fine Gain Factor CH1
		GF2:	Fine Gain Factor CH2
		VOS12:	Offset Reference Source CH1, CH2
		MP1:	VDC Center Potential CH1
		MP2:	VDC Center Potential CH2
		OR1:	Coarse Offset Factor CH1
		OF1:	Fine Offset Factor CH1
		OR2:	Coarse Offset Factor CH2
		OF2:	Fine Offset Factor CH2
		PH12:	Phase Correction CH1 to CH2
Serial I²C Interface	Page 17	Signal Conditioning CH0 (X1, X2)	Page 28
ENFAST:	I ² C Fast Mode	GR0:	Coarse Gain Factor CH0
ENSL:	I ² C Slave Mode	GF0:	Fine Gain Factor CH0
CHKSUM:	Configuration Data Checksum	VOS0:	Offset Reference Source CH0
CHPREL:	Chip Release	OR0:	Coarse Offset Factor CH0
RUN:	Device Enable	OF0:	Fine Offset Factor CH0
Bias Current Source and Temperature Sensor	Page 19	Signal Level Control	Page 29
CFGIBN:	Bias Current	ADJMODE:	Type of Control
CFGTA:	Temperature Monitoring	ADJ(10:9):	Control Deadband
Operating Modes	Page 20	ADJ(8:7):	ACO Output Control Mode
MODE:	Operating Mode	ADJ(6:5):	ACO Output Current Range
ENF:	Signal Filtering	ADJ(4:0):	Square/Sum Control Setpoint
Test Mode	Seite 21	ADJ(4:0):	Current Source Setpoint
TMODE:	Test Mode Functions	Error Monitoring and Alarm Output	Page 31
TMEM:	Test Mode Memory Selection	EPH:	Alarm Output ERR and I/O Logic
DEVID:	Device ID of EEPROM	EMTD:	Min. Indication Time Alarm Outp. ERR
PGA Input Configuration and Signal Path Multiplexer	Page 22	EPU:	Pull-Up Enable Alarm Output ERR
INMODE:	Diff./Single-Ended Input Mode	EMASKA:	Error Mask Alarm Output ERR
RIN12:	I/V Mode and Input Resistance CH1, CH2	EMASKO:	Error Mask Driver Shutdown
BIAS12:	Reference Voltage CH1, CH2	EMASKE:	Error Mask EEPROM Savings
PULL12:	Clamp Resistor CH1, CH2	ERR1:	Error Protocol: First Error
RIN0:	I/V Mode and Input Resistance CH0	ERR2:	Error Protocol: Last Error
BIAS0:	Reference Voltage CH0	ERR3:	Error Protocol: History
MUXIN:	Input Multiplexer	PDMODE:	Driver Activation
INVZ:	Index Signal Inversion		
EAZ:	Index Comparator Enable		
BIASEX:	Input Reference Selection		
BYP	Input-to-Output Bypass		

iC-MSC SIN/COS SIGNAL CONDITIONER WITH FAIL-SAFE 1 Vpp LINE DRIVER

preliminary



Rev A2, Page 15/35

REGISTER MAP

Register Map								
Addr	Bit 7	Bit 6	Bit 5	Bit 4	Bit 3	Bit 2	Bit 1	Bit 0
Configuration Interface								
0x00	ENFAST	DEVID(6:0)						
Calibration								
0x01	CFGIBN(3:0)			CFGTA(3:0)				
Operating Modes								
0x02	RUN*	1	0	PULL12(1)	MODE(3:0)			
Input Configuration and Signal Path Multiplexer								
0x03	EAZ	0	0	0	INVZ	INMODE	MUXIN(1:0)	
Signal Conditioning CH1, CH2								
0x04	GF2(4:0)				GR12(2:0)			
0x05	GF1(7:0)							
0x06	MP1(4:0)				GF1(10:8)			
0x07	MP2(2:0)			MP1(9:5)				
0x08	OR1(0)	MP2(9:3)						
0x09	OF1(6:0)							OR1(1)
0x0A	OF2(1:0)	OR2(1:0)			OF1(10:7)			
0x0B	OF2(9:2)							
0x0C	PH12(6:0)							OF2(10)
0x0D	BIASEX(1:0)	BYP	1	1	PH12(9:7)			
0x0E	ENF	BIAS12	VOS12(1:0)		RIN12(3:0)			
Signal Level Control								
0x0F	ADJ(0)	ADJMODE	0	1	0	0	0	0
0x10	ADJ(8:1)							
Signal Conditioning CH0								
0x11	GF0(4:0)				GR0(2:0)			
0x12	OF0(5:0)					OR0(1:0)		
0x13	PULL12(0)	BIAS0	VOS0(1:0)		RIN0(3:0)			
Error Monitoring and Alarm Output								
0x14	0	EMASKA(6:0)						
0x15	TMODE(1:0)		EMTD(2:0)			EPH	ADJ(10:9)	
0x16	0	EMASKO(6:0)*						
0x17	EMASKE(3:0)				ENSL	EPU	0	0
0x18	TMEM	PDMODE	0	0	0	EMASKE(6:4)*		
0x19.. 0x1A	not defined							
0x1B.. 0x1E	OEM Data							
Checksum / Chip Release								
0x1F	EEPROM: CHKSUM(7:0) / ROM: CHPREL(7:0)							

iC-MSC SIN/COS SIGNAL CONDITIONER WITH FAIL-SAFE 1 Vpp LINE DRIVER

preliminary



Rev A2, Page 16/35

Register Map									
Addr	Bit 7	Bit 6	Bit 5	Bit 4	Bit 3	Bit 2	Bit 1	Bit 0	
Error Register									
0x20	–	ERR1(6:0)							
0x21	ERR2(5:0)						–	–	
0x22	ERR3(3:0)				–	–	–	ERR2(6)	
0x23	–	–	–	–	–	ERR3(6:4)			
Notes	The device RAM initially contains random data following power-on. *) Mandatory programming of EEPROM: RUN = 1, EMASKO(6) = 0, EMASKE(6) = 0.								

Table 4: Register Layout (EEPROM)

SERIAL I²C INTERFACE

The multi-master capable I²C interface consists of two bidirectional pins, SCL (for clock) and SDA (for data), and enables iC-MSC to restore its configuration from the external serial EEPROM. For this function the read-out clock rate is selectable using ENFAST.

Furthermore, the I²C interface can be enabled to operate as an I²C slave (using ENSL), allowing an external I²C master to monitor and edit iC-MSC's configuration data.

ENFAST		Addr. 0x00, bit 7
Code	Function	
0	Regular clock rate, f(SCL) approx. 80 kHz	
1	High clock rate, f(SCL) approx. 320 kHz	
Notes	For in-circuit programming bus lines SCL and SDA require pull-up resistors. For line capacitances of up to 170 pF, adequate values are: 4.7 kΩ with clock frequency 80 kHz 2 kΩ with clock frequency 320 kHz The pull-up resistors may not be less than 1.5 kΩ. To separate the signals a ground line between SCL and SDA is recommended. iC-MSC requires a supply voltage during EEPROM programming (5V to VDD).	

Table 5: I²C Fast Mode

ENSL		Addr. 0x17, bit 3
Code	Function	
0	I ² C slave mode disabled	
1	I ² C slave mode enabled (Device ID 0x55)	

Table 6: I²C Slave Mode

EEPROM Selection

The following minimal requirements must be fulfilled:

EEPROM Device Requirements	
Supply Voltage	3.3 V to 5.5 V
Power-On Threshold	< 3.3 V (due to Elec.Char. 901)
Addressing	11 bit address max.
Device Address	0x50 ('1010 000' w/o R/W bit), 0xA0 ('1010 0000' with R/W = 0)
Page Buffer	Support of <i>Page Write</i> with pages of at least 4 bytes.
Size Minimum	512 bit (64x8 bit) (address range used is 0x00 to 0x3F)
Size Maximum	16 Kbit (8x 256x8 bit), type 24C16

Table 7: EEPROM Device Requirements

EEPROMs beyond 16 Kbit can not be used as those require a 2 byte address. If the EEPROM does not feature *Page Write*, error events can not be saved (EMASKE must be configured to 0x00).

The following devices are recommended: Atmel AT24C01, ST M24C01, ST M24C02 (2K), ROHM BR24L01A-W, BR24L02-W.

ATTENTION: EEPROMs which consider block selection bits as "don't care" should not be used.

Note: When programming the EEPROM in-circuit, note that iC-MSC must be powered up in advance of the EEPROM to avoid interferences from its I²C master.

Device Startup

Once the supply has been switched on (power down reset) the iC-MSC outputs are high impedance (tristate) until a valid configuration is read out from the EEPROM using device ID 0x50.

If the configuration data is not confirmed by its checksum, the readin process is repeated. If no valid configuration data is available after a fourth attempt, iC-MSC terminates communication with the EEPROM and enables I²C slave mode. For timing information, refer to the Electrical Characteristics, items D10 and D11.

For devices loading valid configuration data from the EEPROM, bit ENSL decides whether the I²C slave function is enabled or not.

Configuration Data Checksum

The checksum at address 0x1F is used to initially confirm the configuration data read from the EEPROM.

CHKSUM		Addr. 0x1F, bit 7:0
Code	Function	
0x00... ...0xFF	Checksum for address range 0x00 to 0x1E; CRC polynomial 0x11D ($x^8 + x^4 + x^3 + x^2 + 1$) Start value: 0x01	

Table 8: Configuration Data Checksum

Example of CRC Calculation Routine:

```

unsigned char ucDataStream = 0;
int iCRCPoly = 0x11D;
unsigned char ucCRC=0;
int i = 0;

ucCRC = 1; // start value !!!
    
```

iC-MSC SIN/COS SIGNAL CONDITIONER WITH FAIL-SAFE 1 Vpp LINE DRIVER

preliminary



Rev A2, Page 18/35

```

for (iReg = 0; iReg<31; iReg ++ )
{
    ucDataStream = ucGetValue(iReg);
    for (i=0; i<=7; i++) {
        if ((ucCRC & 0x80) != (ucDataStream & 0x80))
            ucCRC = (ucCRC << 1) ^ iCRCPoly;
        else
            ucCRC = (ucCRC << 1);
        ucDataStream = ucDataStream << 1;
    }
}

```

I²C Slave Mode (ENSL = 1)

In this mode iC-MSC behaves like an I²C slave with the device ID 0x55 and the configuration interface permits reading and writing to and from iC-MSC's internal registers.

For chip release verification purposes an identification value is stored under ROM address 0x1F; writing to this address is not permitted.

CHPREL	Addr. 0x1F, bit 7:0 (ROM)
Code	Chip Release
0x40	iC-MSC 0

Table 9: Chip Release

RUN	Addr. 0x02, bit 7
Code	Function
0	Device standby: output drivers disabled (tristate)
1	Device enabled: output drivers active (configuration data must be valid)
Notes	RUN is evaluated only during I ² C slave mode. Writing changes the function. Reading does not return the chip's state.

Table 10: Device Enable

Register	Read access in I ² C slave mode (ENSL = 1)
Address	Content
0x00...18	Configuration: register addresses 0x00...0x18
0x19...1A	Not available
0x1B...1E	OEM data (4 bytes) (see EEPROM addresses 0x1B...0x1E)
0x1F	Chip release (ROM)
0x20...23	Configuration: register addresses 0x20-0x23
0x24...37	Not available
0x38	Configuration: register address 0x18
0x39...3A	Not available
0x3B...3E	OEM data (4 bytes) (see EEPROM addresses 0x1B...0x1E)
0x3F	Chip release (ROM)
0x40...43	Current error memory (only active if enabled by EMASKE; messages are transferred to EEPROM addresses 0x20...0x23)
0x44...7F	Not available

Table 11: RAM Read Access

Register	Write access in I ² C slave mode (ENSL = 1)
Address	Access and conditions
0x00	Changes possible, no restrictions
0x01	Changes possible (wrong entries for CFGIBN can limit functions)
0x02	Bit 7 = 0 (RUN): changes to bits (6:0) permitted A change of operating mode follows only on writing Bit 7 = 1 (RUN); when doing so, changes to bits (6:0) are not permitted.
0x03...16	Changes possible, no restrictions
0x17	Bit 3 = 1 (ENSL): changes to bits (7:4) and (2:0) permitted
0x18	Changes possible, no restrictions
0x19...1A	Not available
0x1B...1E	Changes possible, no restrictions
others	No changes permitted

Table 12: RAM Write Access

BIAS CURRENT SOURCE AND TEMPERATURE SENSOR

Bias Current Calibration

The calibration of the bias current source in operating mode *Calibration 1* (refer to Table 15 for an overview of operating modes) is required to adhere to the given Electrical Characteristics and also instrumental in determining the chip timing (e.g. SCL clock frequency).

The IBN bias current is measured by connecting pin **VDDS** and pin **NC** with a 10 kΩ resistor. When the voltage drop is 2 V, the bias current is adjusted to its target value of 200 μA.

Note: The outputs may not be tristate when measuring the IBN bias current. Therefore, a virgin EEPROM must first be configured (e.g. by a default setup with CRC) and the power cycled to obtain active outputs.

CFGIBN Addr. 0x01, bit 7:4			
Code k	IBN ~ $\frac{31}{39-k}$	Code k	IBN ~ $\frac{31}{39-k}$
0x0	79 %	0x8	100 %
0x1	81 %	0x9	103 %
0x2	84 %	0xA	107 %
0x3	86 %	0xB	111 %
0x4	88 %	0xC	115 %
0x5	91 %	0xD	119 %
0x6	94 %	0xE	124 %
0x7	97 %	0xF	129 %

Table 13: Bias Current

Temperature Sensor Calibration

The temperature monitoring is calibrated in operating mode *Calibration 3* (refer to Table 15 for an overview of operating modes).

First, the temperature sensor voltage at which the warning message is generated, VTs, must be determined. A voltage ramp from VDDS towards GNDS is applied to pin PS until pin ERR pulls low (at approx. 4.4 V when coming from 5.0 V). The following settings are required for this measurement: EMASKA = 0x20 (excessive temperature warning enabled), EMTD = 0x00 (shortest alarm indication time), and EPH = 0x00 (alarm output active low).

Note that the signal at pin ERR switches from tristate to low (on reaching VTs) and already at just 25 mV lower

from low to tristate (on overshooting the temperature shutdown threshold, which is not relevant to calibration). To avoid confusion, a clear change of state (from high → low → high) should be generated using an external pull-up resistor at pin ERR.

Example: VTs(T₁) is approx. 640 mV, measured from VDDS versus PS, with T₁ = 25 °C;

The necessary warning activation threshold, VTth(T₁), is then calculated. The required warning temperature T₂, temperature coefficients TCs and TCth (see Electrical Characteristics, Section E), and measurement value VTs(T₁) are entered into this calculation:

$$VTth(T_1) = \frac{VTs(T_1) + TCs \cdot (T_2 - T_1)}{1 + TCth \cdot (T_2 - T_1)}$$

Example: for T₂ = T₁ + 100 K VTth(T₁) must be programmed to 434 mV.

Reference voltage VTth(T₁) is provided for a high impedance measurement (10 MΩ) at output pin NS (measurement against VDDS) and must be set to the calculated value by programming CFGTA(3:0).

Example: altering VTth(T₁) from 315 mV (measured with CFGTA(3:0) = 0x0) to 434 mV is equivalent to 138 %, the closest value for CFGTA is 0x8;

CFGTA Addr. 0x01, bit 3:0			
Code k	VTth ~ $\frac{65 + 3.25k}{65}$	Code k	VTth ~ $\frac{65 + 3.25k}{65}$
0x0	100 %	0x8	140 %
0x1	105 %	0x9	145 %
0x2	110 %	0xA	150 %
0x3	115 %	0xB	155 %
0x4	120 %	0xC	160 %
0x5	125 %	0xD	165 %
0x6	130 %	0xE	170 %
0x7	135 %	0xF	175 %
Notes	CFGTA = 0xC: Tw is approx. 85 °C, and Toff is approx. 97 °C typically. CFGTA = 0x8: Tw is approx. 125 °C, and Toff is approx. 137 °C typically.		

Table 14: Temperature Monitoring

iC-MSC SIN/COS SIGNAL CONDITIONER WITH FAIL-SAFE 1 Vpp LINE DRIVER

preliminary



Rev A2, Page 20/35

OPERATING MODES

The iC-MSC has several operating modes, for which the functions of outputs PS, NS, PC, NC, PZ, NZ and ERR are different.

impedance. The output drivers and the reverse polarity protection feature are not active during Calibration and Test modes.

In order to condition the input signals and to calibrate and test the iC-MSC, various Calibration and Test modes are available. The analog test signals which are provided must always be measured at high load

During Normal operating mode the line drivers are engaged to allow driving terminated lines (by 1 Vpp signals into 120 Ω), and also the reverse polarity protection feature is active.

MODE(3:0)		Addr. 0x02; bit 3:0						
BYP		Addr. 0x0D; bit 5						
Code	Operating Mode	Pin PS	Pin NS	Pin PC	Pin NC	Pin PZ	Pin NZ	Pin ERR
0x00	Normal operation	PS	NS	PC	NC	PZ	NZ	ERR
0x01	Calibration 1	TANA0(2)	VREFI0	VREFI12	IBN	PZI	NZI	ERR
0x02	Calibration 2, BYP = 0 Calibration 2, BYP = 1*	PCH1 X4	NCH1 X6	PCH2 X3	NCH2 X5	VDC1 X1	VDC2 X2	—
0x03	iC-Haus Test 1	VPAH	VPD	—	CGUCK	IPF	V05	IERR
0x04	iC-Haus Test 2	PS_out	NS_out	PC_out	NC_out	PZ_out	NZ_out	IERR
0x05	iC-Haus Test 3	PS_out	NS_out	PC_out	NC_out	PZ_out	NZ_out	ERR
0x06	iC-Haus Test 4, BYP = 0 iC-Haus Test 4, BYP = 1*	TANA12(0) X4	TANA12(1) X6	TANA12(2) X3	TANA12(3) X5	TANA12(4) X1	TANA12(5) X2	IERR
0x07	Calibration 3	VTs	VTth	—	—	—	—	ERR
0x08	Saturation low	SCL, SDA and ERR low						
0x09	—	—	—	—	—	—	—	—
0x0A	iC-Haus Test 5	—	—	TP	CLK6	—	—	—
0x0B	—	—	—	—	—	—	—	—
0x0C	—	—	—	—	—	—	—	—
0x0D	—	—	—	—	—	—	—	—
0x0E	IDDQ-Test	All PU/PD resistors, oscillator and supply voltage deactivated						
0x0F	—	—	—	—	—	—	—	—
Notes	Analog calibration signals are output via approx. 5 kΩ source impedance (see Elec. Char. No. 506). For accuracy of calibration the signal frequency should not exceed 2 kHz (see Elec. Char. No. 507). * Bypass function: inputs (without voltage divider) to outputs, approx. 7 kΩ source impedance (see Elec. Char. No. 508).							

Table 15: Operating Modes

Calibration Op. Modes

In mode *Calibration 1* the user can measure the BIAS current (IBN), input amplifier reference potential VREFI and the analog signals from channel 0 following signal conditioning (PCH0 and NCH0).

In mode *Calibration 2* the conditioned signals from channels 1 and 2 are output (PCH1, NCH1, and PCH2, NCH2). In addition, the VDC offset references generated in the input circuits are also available for calibration of their center potentials (CH1: VDC1, CH2: VDC2).

In mode *Calibration 3* the internal temperature monitoring signals are provided.

Special Device Test Functions

IDDQ-Test, *Saturation Low*, *Saturation High*, and *Test 1 to 5* are test modes for iC-Haus device tests. With

an activated bypass (BYP = 1), mode *iC-Haus Test 4* permits the direct feedthrough of X1 - X6 input signals to the output pins; in this instance the output's source impedance is quite high. Furthermore, if the input voltage divider is selected (by RINx = 1--1), it reduces the signal amplitudes to approx. 7/8 of the original.

Signal Filter

iC-MSC has a noise limiting signal filter to smooth the conditioned analog signals. This can be activated using ENF.

ENF		Addr. 0x0E, bit 7
Code	Function	
0	Noise limiter deactivated	
1	Noise limiter activated	

Table 16: Signal Filtering

PGA INPUT CONFIGURATION

All input stages are configured as instrumentation amplifiers and thus directly suitable for differential input signals. Single-ended input signals can be processed by applying the input signal's reference voltage to the negative inputs, or rather to X2, when using the single-ended input configuration.

Both voltage and current signals can be accepted as input signals. For selection, use registers RIN12 and RIN0.

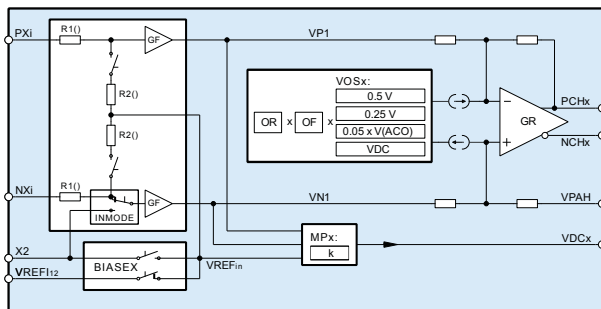

Figure 2: Signal conditioning input circuit.

Voltage Signals

In voltage mode (V-Mode), an optional voltage divider can be selected for high input amplitudes. This voltage divider reduces the input signal's amplitude to 25 % of the original. The internal circuit corresponds to the circuit in current mode, just the in-line resistor R1 is altered.

Current Signals

In current mode (I-Mode), an internal resistor R2() becomes active at each input, converting the current signal into a voltage signal. The effective input resistance Rin() is always determined by the sum of R1 and R2, whereas R2 links to the selectable reference voltage VREFin.

R2 should be set to obtain approx. 125 mV to 250 mV for the VDC offset references (for VDC1 and VDC2, using operating mode Calibration 2).

Note: The input circuit is not suitable for back-to-back photodiodes.

INMODE	
Code	Function
0	Differential input signals
1	Single-ended input signals *
Note	* Input X2 is reference for all inputs.

Table 19: Diff./Single-Ended Input Mode

RIN12		RIN0	
Addr. 0x0E, bit 3:0		Addr. 0x13, bit 3:0	
Code	In-line R1()	Internal R2()	I/V Mode
-000	0.1 kΩ	1.6 kΩ	I-Mode
-010	0.2 kΩ	2.3 kΩ	I-Mode
-100	0.3 kΩ	3.2 kΩ	I-Mode
-110	0.3 kΩ	4.6 kΩ	I-Mode
0—1	3.5 kΩ	See Table 23	V-Mode 1:1*
1—1	15 kΩ	5 kΩ	V-Mode 4:1*
Notes	Nominal values; Rin = R1() + R2(); for tolerances refer to Elec.Char. No. 107, 108, 210, 211. VREFin is the voltage divider's footpoint. Input currents may be positive or negative (Vin > VREFin, or Vin < VREFin). When using X2 as reference and single-ended input configuration (INMODE = 1), use RIN12 = RIN0. *) See Elec.Char. No. 101 for permissible input voltage range.		

Table 20: I/V Mode and Input Resistance

Input Reference Voltages

The parameters BIAS12 and BIAS0 determine the input circuit's internal reference voltages VREFI12 and VREFI0.

In the generation of the VDC offset references, BIAS12 also determines whether the reference voltage VREFin is subtracted from the sum of the particular input signals or the sum is subtracted from VREFin.

BIAS12		BIAS0	
Addr. 0x0E, bit 6		Addr. 0x13, bit 6	
Code	Function		
0	VREFI = 2.5 V for low-side current sinks (e.g. photodiodes with common anode at GNDS) Note*: V(PXi) + V(NXi) < 2 x VREFin		
1	VREFI = 1.5 V for high-side current-sources (e.g. photodiodes with common cathode at VDD5) for voltage sources relative to ground (e.g. iC-SM2, Wheatstone sensor bridges) for voltage sources with low-side reference (e.g. iC-LSHB, when using BIASEx = 11) Note*: V(PXi) + V(NXi) > 2 x VREFin		
Notes	*) Condition is relevant only if using - the VDC offset references (see Table 31) - the input voltage divider (see Table 20) - sum control mode (see Table 42)		

Table 21: Reference Voltage

In the generation of the VDC offset references it is also essential that the input circuit refers to the same footpoint as the incoming sensor signals.

For footpoint levels above ground, BIASEX = 11 allows both internal VREF_{I12} and VREF_{I0} sources to be replaced by the sensor's reference voltage, connected as VREF_{ex} to input X2.

Vice versa, using BIASEX = 10, iC-MSC's internal VREF_{I12} can be output to X2, to be used as reference for the external sensor circuit (using an opamp for buffering is required).

Note that whenever X2 is used to output VREF_{I12} or to input VREF_{ex}, the internal reference VREF_{in} is always the same for CH1, CH2, and CH0.

BIASEX	Addr. 0x0D, bit 7:6	
Code	X2 Function	Input Reference Voltage
00	Input X2 ← Index-	VREF _{in12} = VREF _{I12} VREF _{in0} = VREF _{I0}
10	Output* VREF _{I12} → X2	VREF _{in12} = VREF _{in0} = VREF _{I12}
11	Input** X2 ← VREF _{ex}	VREF _{in12} = VREF _{in0} = VREF _{ex}
Notes	*) Output signal should be buffered. **) See Elec. Char. Nos. 208 and 209.	

Table 22: Input Reference Selection

Input Clamping Resistors

For ease of detection of a broken sensor wire, optional input clamping resistors can be enabled using PULL12. When a connection fails, the corresponding input clamping resistor reduces the input amplitude to trigger signal monitoring alarms.

Note: Using the built-in clamping resistors may not fulfill the application requirements for functional safety.

PULL12(1) Addr. 0x02, bit 4	
PULL12(0) Addr. 0x13, bit 7	
Code	Function
0	1 MΩ clamp resistor at PXi and NXi against VREF _{in}
1	1 MΩ clamp resistor at PXi and NXi against X2
2	1 MΩ clamp resistor at PXi and NXi against GNDS
3	No clamp resistor at PXi and NXi
Note	CH0 includes fixed 2 MΩ resistor between X1, X2

Table 23: Input Clamping CH1, CH2

Examples of Permissible Input Voltages

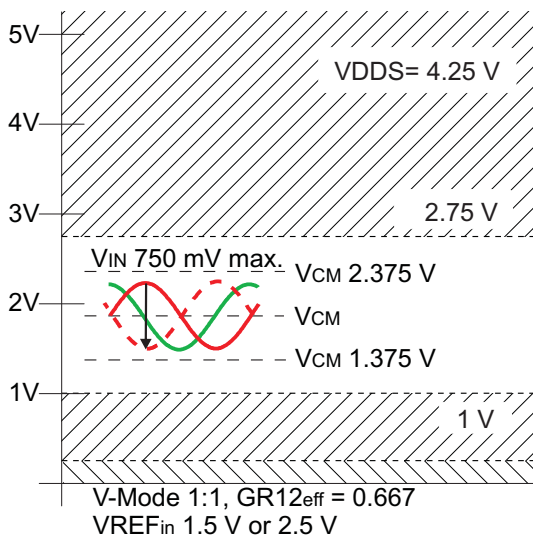

Figure 3: Permissible maximum input amplitude V_{IN} and common mode input range V_{CM} for G12_{eff} = 0.667 and V-Mode 1:1.

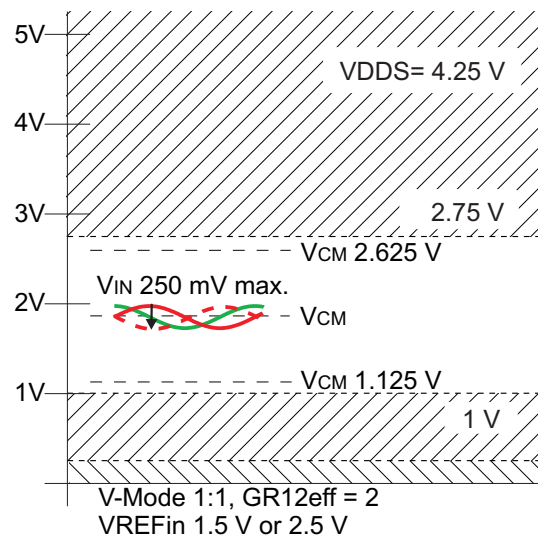

Figure 4: Permissible maximum input amplitude V_{IN} and common mode input range V_{CM} for G12_{eff} = 2.0 and V-Mode 1:1.

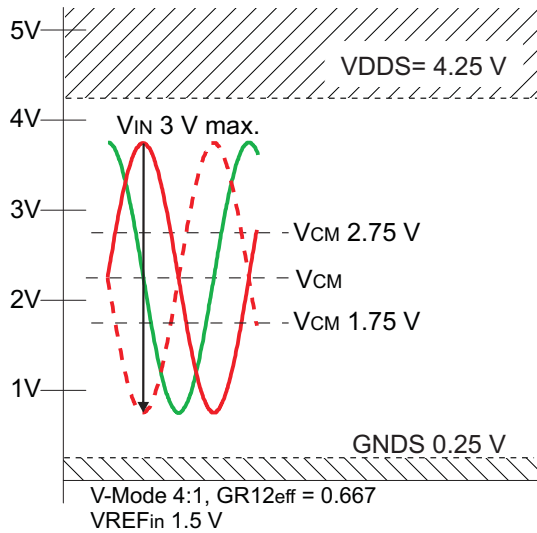

Figure 5: Permissible maximum input amplitude V_{IN} and common mode input range V_{CM} for $G_{12\text{eff}} = 0.667$ and V-Mode 4:1.

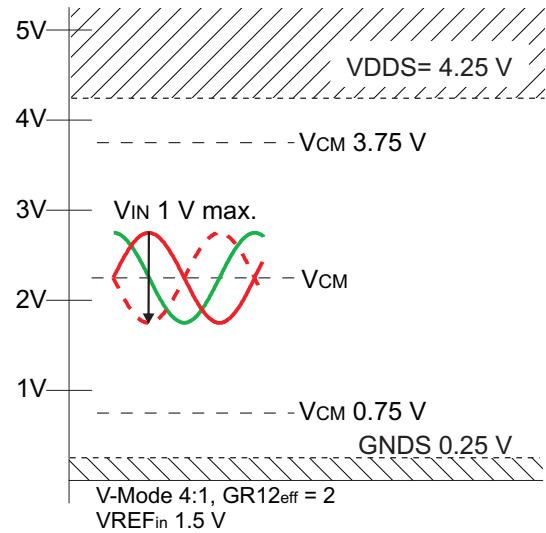

Figure 6: Permissible maximum input amplitude V_{IN} and common mode input range V_{CM} for $G_{12\text{eff}} = 2.0$ and V-Mode 4:1.

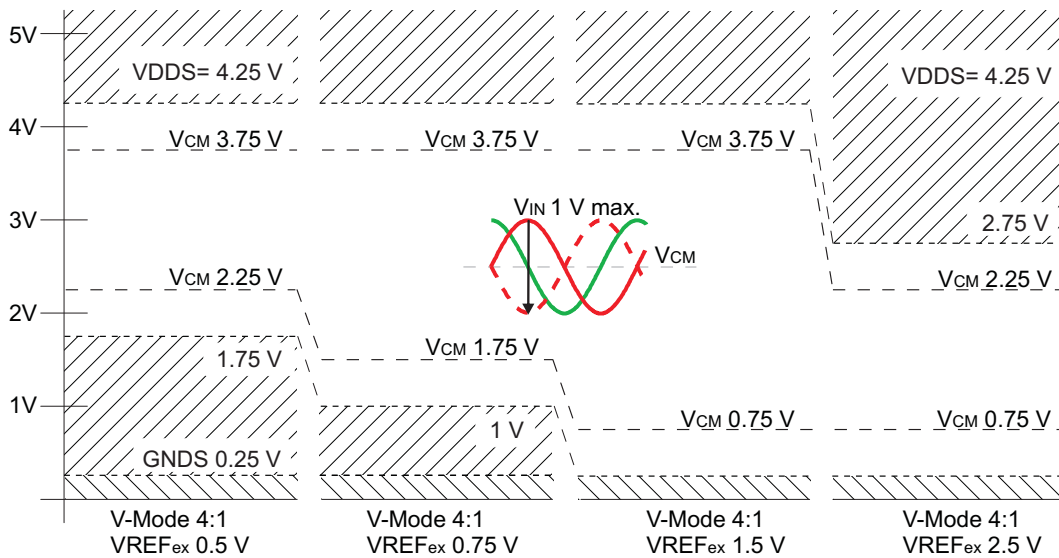

Figure 7: Permissible maximum input amplitude V_{IN} and common mode input range V_{CM} for $G_{12\text{eff}} = 2.0$ and V-Mode 4:1 in dependency to the reference voltage.

SIGNAL PATH MULTIPLEXING

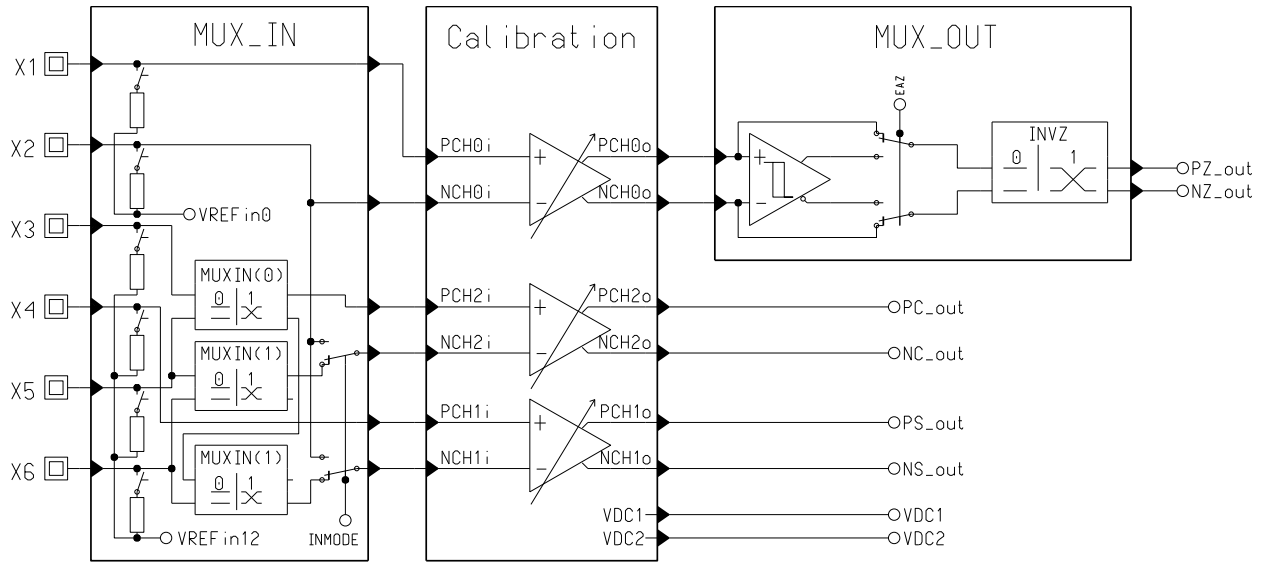

Figure 8: Multiplexer Schematics

The index signals for channel CH0 are to be connected to pins X1 and X2, and the positive-going sine signal for channel CH1 to pin X4.

For the pins X3 to X6, a flexible allocation to channel CH1 and CH2 is possible using MUXIN.

INMODE can be activated for single-ended, referenced input signals; this then selects pin X2 as the reference input (refer to Table 19, page 22).

INVZ allows to invert the index signal's output phase.

EAZ permits the activation of an analog comparator for index channel CH0. When enabled, the PZ and NZ outputs deliver a compared index signal with analog high and low levels, which are generated from the square control's quadrature circuit. Thus, the differential output amplitude at PZ versus NZ follows the square control's setpoint (refer to ADJ(4:0), Table 45, page 29).

Note: When the PZ and NZ outputs show a ripple using EAZ=1, the sin/cos signals of CH1 and CH2 may not have been calibrated accurately.

MUXIN 0x03, bit 1:0				
Code	PCH1i	NCH1i	PCH2i	NCH2i
00	X4	X6	X3	X5
01	X4	X6	X5	X5
10	X4	X5	X3	X6
11	X4	X3	X5	X6

Table 24: Input Multiplexer for INMODE = 0

MUXIN 0x03, bit 1:0				
Code	PCH1i	NCH1i	PCH2i	NCH2i
-0	X4	X2	X3	X2
-1	X4	X2	X5	X2

Table 25: Input Multiplexer for INMODE = 1

INVZ Addr. 0x03, bit 3		
Code	PZ_out	NZ_out
0	PCH0o	NCH0o
1	NCH0o	PCH0o

Table 26: Index Signal Inversion

EAZ Addr. 0x03, bit 7	
Code	Function
0	Comparator bypass
1	Comparator active

Table 27: Index Comparator Enable

SIGNAL CONDITIONING CH1, CH2

The voltage signals necessary for the conditioning of channels 1 and 2 can be measured in operating mode *Calibration 2*.

Gain Settings

The gain is set in four steps:

1. The signal level control is to be shut down and the constant current source for the ACO output is set to a suitable output current (register ADJ; a value close to the later operating point).
2. The coarse gain factor is selected so that differential signal amplitudes of approx. 1 Vpp are to be produced (signal Px vs. Nx, see Figure below).
3. Using fine gain factor GF2, the CH2 signal amplitude is then to be adjusted to exactly 1 Vpp.
4. Finally, the CH1 signal amplitude can then be adjusted precisely to the CH2 signal amplitude via fine gain factor GF1.

This results in a total gain of GR12 x GFx for differential input signals.

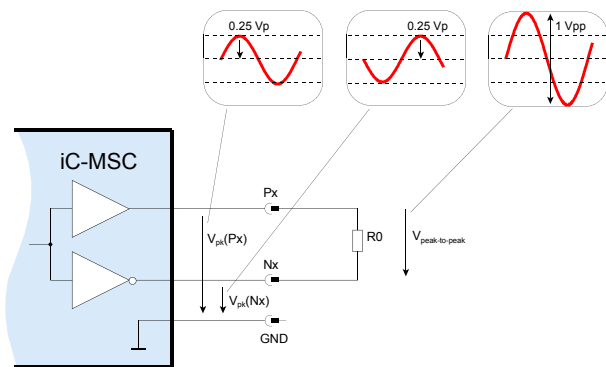

Figure 9: Definition of 1 Vpp differential signal. Termination R0 must be high-impedance (resistive) during all *Test* and *Calibration* modes.

GR12	
Addr. 0x04, bit 2:0	
Code	Factor
0x0	0.667
0x1	2.0
0x2	4.1
0x3	6.7
0x4	8.7
0x5	10.5
0x6	13.2
0x7	16.0
Notes	The effective total gain is calculated using: $G12_{eff} = GFx \times GR12$, or $G12_{eff} = 1/4 \times GFx \times GR12$ if using the input voltage divider (RIN12 = 0x9).

Table 28: Coarse Gain Factor CH1, CH2

GF2	
Addr. 0x04, bit 7:3	
Code	Factor
0x00	1.00
0x01	1.06
...	$6.25^{\frac{Code}{31}}$
0x1F	6.25

Table 29: Fine Gain Factor CH2

GF1	
Addr. 0x06, bit 2:0, Addr. 0x05, bit 7:0	
Code	Factor
0x000	1.0
0x001	1.0009
...	$6.25^{\frac{Code}{1984}}$
0x7FF	6.6245

Table 30: Fine Gain Factor CH1

Offset Calibration

In order to calibrate the offset the reference source must first be selected using VOS12. Two fixed voltages and two dependent sources are available for this purpose. The fixed voltage sources should be selected for external sensors which provide stable, self-regulating signals.

So that photosensors can be operated in optical encoders iC-MSC tracks changes in offset voltages via the signal-dependent source VDC when used in conjunction with the controlled sensor current source for LED supply (pin ACO). The VDC potential automatically tracks higher DC photocurrents. To do this, the center potentials for the VDC offset references can be adjusted to minimize their AC ripple, using parameters MP1 for VDC1, and MP2 for VDC2 (refer to the k factor of Table 32).

The feedback of pin voltage V(ACO) fulfills the same task as the VDC offset references when MR bridge sensors are supplied by the ACO output (using the controlled current source), or by supply VDDS (with pin ACO linked to VDDS to measure the bridge's supply).

VOS12		Addr. 0x0E, bit 5:4
Code	Type of source	
0x0	Feedback of ACO pin voltage: V(ACO)/20 for sensor supply-dependent diff. voltage signals for Wheatstone sensor bridges to measure VDDS (relative to GNDS)	
0x1, 0x2	Fixed reference: V05 of 500 mV, V025 of 250 mV for single-ended current or voltage signals for single-ended or differential stabilized signals (regulated sensor or waveform generator)	
0x3	Self-tracking VDC offset references (125...250 mV) for differential current signals for differential voltage signals (measured relative to VREFin*)	
Notes	*) Requires BIASEX = 11 and the sensor's reference level connected to input X2 (see Elec. Char. No. 201 for acceptable input voltage).	

Table 31: Offset Reference Source CH1, CH2

MP1		Addr. 0x07, bit 4:0; Addr. 0x06, bit 7:3
MP2		Addr. 0x08, bit 6:0; Addr. 0x07, bit 7:5
Code	VDCi = (1 - k) · VPi + k · VNi	
0x000	k = 1/3	
0x001	k = 0.3337	
...	k = 1/3 + 1/3 · Code/1023	
0x200	k = 0.5000 (center setting)	
...	...	
0x3FF	k = 2/3	
Notes	Adjustment is required only if VOS12 = 0x3	

Table 32: VDC Center Potential CH1, CH2

The offset calibration range for CH1 and CH2 is set using the coarse offset factors OR1 and OR2. Both sine and cosine signals are then calibrated using the fine offset factors OF1 and OF2. The calibration target is reached when the DC component of the differential signals PCHx to NCHx is zero.

OR1		Addr. 0x09, bit 0; Addr. 0x08, bit 7
OR2		Addr. 0x0A, bit 5:4
Code	Factor	
0x0	1	
0x1	2	
0x2	6	
0x3	12	

Table 33: Coarse Offset Factor CH1, CH2

OF1		Addr. 0xA, bit 3:0; Addr. 0x9, bit 7:1
OF2		Addr. 0xC, bit 0; Addr. 0xB, bit 7:0; Addr. 0xA, bit 7:6
Code	Factor	
0x000	0	
0x001	0.00098	
...	+ Code/1023	
0x3FF	+ 1	
0x400	0	
0x401	- 0.00098	
...	- (Code - 1024)/1023	
0x7FF	- 1	

Table 34: Fine Offset Factor CH1, CH2

Phase Correction CH1 to CH2

The phase shift between CH1 and CH2 can be adjusted using parameter PH12. After phase calibration other calibration parameters may have to be adjusted again (those as amplitude compensation, center potentials and offset voltages).

PH12		Addr. 0xD, bit 2:0; Addr. 0xC, bit 7:1
Code	Correction angle	
0x000	0°	
0x001	+ 0.0204°	
...	+ 10.42° · Code/511	
0x1FF	+ 10.42°	
0x200	0°	
0x201	- 0.0204°	
...	- 10.42° · (Code - 512)/511	
0x3FF	- 10.42°	

Table 35: Phase Correction CH1 to CH2

SIGNAL CONDITIONING CH0

The test signals required to calibrate channel 0 are available in mode *Calibration 1*.

Gain Settings CH0

The CH0 gain is set using the following steps:

1. The signal level control is to be shut down and the constant current source for the ACO output set to the same values as during the calibration of CH1 and CH2 (register ADJ; current value close to the later operating point).
2. The coarse gain is to be selected so that a differential signal amplitude of approx. 1 Vpp is produced (signal PCHx to NCHx).
3. GF0 then permits fine gain adjustment to 1 Vpp. The resulting gain is GR0 x GF0.

GR0 Addr. 0x11, bit 2:0	
Code	Factor
0x0	0.667
0x1	2.0
0x2	4.1
0x3	6.7
0x4	8.7
0x5	10.5
0x6	13.2
0x7	16.0
Notes	The effective total gain is calculated using: $G_{0\text{eff}} = GF0 \times GR0$, or $G_{0\text{eff}} = 1/4 \times GF0 \times GR0$ if using the input voltage divider (RIN0 = 0x9).

Table 36: Coarse Gain Factor CH0

GF0 Addr. 0x11, bit 7:3	
Code	Factor
0x00	1.00
0x01	1.06
...	$6.25 \frac{GFZ}{31}$
0x1F	6.25

Table 37: Fine Gain Factor CH0

Offset Calibration CH0

The offset reference source is selected with VOS0. The offset compensation is set with OR0 and OF0 (see Offset Calibration CH1 and CH2 for further information). When selecting the self-tracking VDC offset reference, the source VDC1 of channel 1 is used.

VOS0 Addr. 0x13, bit 5:4	
Code	Source
0x0	$0.05 \cdot V(\text{ACO})$
0x1	0.5 V
0x2	0.25 V
0x3	VDC (= VDC1)

Table 38: Offset Reference Source CH0

OR0 Addr. 0x12, bit 1:0	
Code	Factor
0x0	1
0x1	2
0x2	6
0x3	12

Table 39: Coarse Offset Factor CH0

OF0 Addr. 0x12, bit 7:2	
Code	Factor
0x00	0
0x01	0.0322
...	$+ \text{Code}/31$
0x1F	1
0x20	0
0x21	-0.0322
...	$- (\text{Code} - 32)/31$
0x3F	-1

Table 40: Fine Offset Factor CH0

SIGNAL LEVEL CONTROL and SIGNAL MONITORING

iC-MSC's signal level control can keep the input signals for the sine/cosine signal conditioning circuit constant, regardless of temperature and aging effects, when using control output ACO to track the sensor supply.

ADJ(6:5) presets the output current range of pin ACO, the control's highside current source output, and ADJ(8:7) defines its control mode.

The control's operating range and the resulting internal signal amplitude are both monitored and thus can be used for error messaging.

ADJ (6:5) Addr. 0x10, bit 5:4	
Code	Current Range
00	0.05 mA ... 5 mA
01	0.1 mA ... 10 mA
10	0.25 mA ... 25 mA
11	0.5 mA ... 50 mA
Note	The range defines the ACO output's guaranteed driving capability. Refer to Elec. Char. No. 602 for the corresponding short-circuit current.

Table 41: ACO Output Current Range (applies for control modes and constant current source)

ADJ (8:7) Addr. 0x10, bit 7:6	
Code	Operating Mode
00	Sine/cosine square control
01	Sum control
10	Constant current source
11	Not permitted (device test only)

Table 42: ACO Output Control Mode

Deadband Control

Using deadband control mode (refer to ADJMODE), a deviation of the signal level is balanced only if the configured control deadband is exceeded (refer to ADJ(10:9)). Using this hysteresis, the square control's influence on the sensor's signal quality (THD) can be significantly reduced.

Using continuous control mode, any level deviation will be balanced immediately over the ACO output.

ADJMODE Addr. 0x0F, bit 6	
Code	Function
0	Deadband control
1	Continuous control
Note	This function is available with <i>square control</i> and <i>sum control</i> modes.

Table 43: Type of Control

ADJ (10:9) Addr. 0x15, bit 1:0	
Code	Hysteresis to setpoint
0x0	2.5%
0x1	5%
0x2	7.5%
0x3	10%

Table 44: Control Deadband

Square Control Mode

The standard control mode is *square control* which uses $(\sin^2 + \cos^2)$ to adjust the ACO output current. ADJ(4:0) determines the internal signal amplitudes within the closed-loop control and, simultaneously, the amplitude monitoring thresholds. The ideal setting is when the sin/cos test signals available in operating mode *Calibration 2* are at 500 mVpp.

ADJ (4:0) Addr. 0x10, bit 3:0; Addr. 0x0F, bit 7	
Code	Square control ADJ(8:7) = 00
0x00	$V_{pp}() \approx 300 \text{ mV} (60 \%)$
0x01	$V_{pp}() \approx 305 \text{ mV} (61 \%)$
...	... $\approx 300 \text{ mV} \frac{77}{77 - (1.25 * Code)}$
0x19	$V_{pp}() \approx 500 \text{ mV} (98 \%)$
...	...
0x1F	$V_{pp}() \approx 600 \text{ mV} (120 \%)$

Table 45: Square Control Setpoint (internal sin/cos signal amplitude)

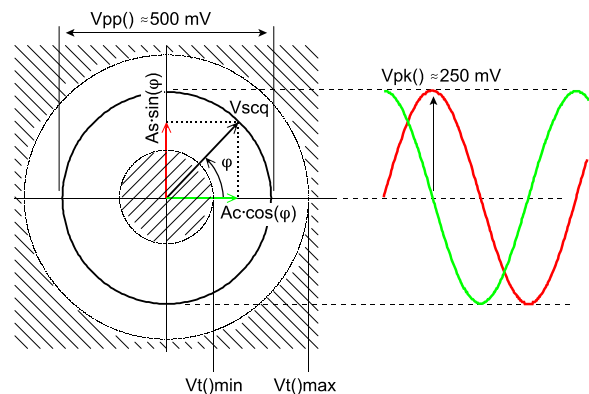

Figure 10: Internal signal monitoring and test signals in mode *Calibration 2* (example for ADJ(8:0) = 0x19);

The signal monitoring thresholds are tracked according to ADJ(4:0) and fit for *square control mode*. When using *sum control mode* a different operating point may be required for which the monitoring thresholds may

not be suitable. In this case signal monitoring should be disabled via the error mask (see EMASKA etc.).

Signal monitoring and thresholds			
ADJ (4:0)	Vt()min ... max	ADJ (4:0)	Vt()min ... max
0x00	120 mV...390 mV	0x19	200 mV ...650 mV
0x01	122 mV...397 mV
...	...	0x1F	240 mV...780 mV
Notes	All values nominal, see also Elec. Char. Nos. 607, 608		

Table 46: Signal Monitoring

Note: Following power up and after the configuration data has been read successfully, the sine/cosine square control starts operation from a zero output current.

Note: Excessive input signals or internal signal clipping can interfere with the control operation, so that the preset operating point may not be reached (upon power up) or maintained (upon disturbances). Use Control Error 2 and Signal Error 1 for monitoring and configuring EMASKA accordingly.

Sum Control Mode

With *sum control* mode selected, the DC references (VDC1 + VDC2) are used to adjust the output current of pin ACO.

ADJ (4:0)		Addr. 0x10, bit 3:0; Addr. 0x0F, bit 7
Code	Sum control ADJ(8:7) = 01	
0x00	VDC1 + VDC2 \approx 245 mV	
0x01	VDC1 + VDC2 \approx 249 mV	
...	...	$\approx 245mV \frac{77}{77-(1.25*Code)}$
0x1F	VDC1 + VDC2 \approx 490 mV	

Table 47: Sum Control Setpoint (DC average)

Constant Current Source

The *constant current source* is intended for signal conditioning purposes, i.e. for the adjustment of gain, offset and phase correction values independent of signal level controlling.

ADJ (4:0)		Addr. 0x10, bit 3:0; Addr. 0x0F, bit 7
Code	Constant current source ADJ(8:7) = 10	
0x00	I(ACO) \approx 3.125% Isc(ACO)	
0x01	I(ACO) \approx 6.25% Isc(ACO)	
...	...	$\approx 3.125% * (Code + 1) * Isc(ACO)$
0x1F	I(ACO) \approx 100% Isc(ACO)	
Note	The setpoint defines the ACO output current relative to Isc(ACO), the output's short-circuit current (see Elec. Char. No. 602) which depends on the selected range.	

Table 48: Current Source Setpoint (ACO output current)

ERROR MONITORING AND ALARM OUTPUT

The following table gives the errors which can both be recognized by iC-MSC and enabled either for messaging, output shutdown or protocol in the EEPROM.

Mask EMASKA stipulates that errors should be signaled at pin ERR, mask EMASKO determines whether the line drivers are to be shutdown or not (with PDMODE defining reactivation) and mask EMASKE governs the storage of error events in the EEPROM.

EMASKA	Addr. 0x14, bit 6:0
EMASKO	Addr. 0x16, bit 6:0
EMASKE	Addr. 0x18, bit 2:0; Addr. 0x17, bit 7:4
Bit	Error Event
6*	Configuration error (SDA or SCL pin error, no acknowledge signal from EEPROM or invalid checksum);
5	Excessive temperature warning
4	External system error
3	Control error 2: range at max. limit
2	Control error 1: range at min. limit
1	Signal error 2: clipping
0	Signal error 1: loss of signal (wrong s/c phase, poor differential amplitude, may also result from excessive input signals or internal signal clipping)
EMASKA	Error Mask Alarm Output ERR
1	Enable: event changes state of pin ERR (if EMASKO does not disable the output function).
0	Disable: event does not affect pin ERR.
*Note	EMASKA(6): Pin ERR can not pull low on config. error. Use EPH = 1 for high-active error logic.
EMASKO	Error Mask Driver Shutdown
1	Enable: event resets pin ACO to the 5 mA range, tristates the line driver outputs and pin ERR (i.e. low-active error messages can not be displayed)
0	Disable: output functions remain active
*Note	EMASKO(6) = 1 (ROM bit): The line drivers remain high impedance (tristate) when cycling power. Program EMASKO(6) = 0 to EEPROM. This allows to reactivate disabled output drivers by toggling bit RUN (set zero, then one). If set to 1, the driver shutdown persists and can not be resolved.
EMASKE	Error Mask EEPROM Savings
1	Enable: event will be latched
0	Disable: event will not be latched
*Note	Program EMASKE(6) = 0 to EEPROM. This avoids conflicts with I ² C programming adapters which are not multi-master capable.

Table 49: Error Masking

Alarm Output: I/O pin ERR

Pin ERR is operated by a current-limited open-drain output driver and has an internal pull-up which can be disabled. The output logic (low or high active) is con-

figured by EPH, and the minimum indication time by EMTD.

Pin ERR also acts as an input for error messages of the external system. This function requires EPH = 0 and an external error being low active. Pin ERR can also switch iC-MSC to test mode, for which a voltage of larger than VTMon must be applied (see page 21).

EPH	Addr. 0x15, bit 2	
Code	State with error	State w/o error
0*	active low	high impedance (evaluation of low active external system error)
1	high impedance (or optional pull-up)	active low
Note	*) Pin ERR is disabled during driver shutdown and cannot indicate errors in this case.	

Table 50: Alarm Output ERR and I/O Logic

EMTD	Addr. 0x15, bit 5:3			
Code	Indication Time	Code	Indication Time	
0x0	0 ms	0x4	50 ms	
0x1	12.5 ms	0x5	62.5 ms	
0x2	25 ms	0x6	75 ms	
0x3	37.5 ms	0x7	87.5 ms	

Table 51: Min. Indication Time, Alarm Output ERR

EPU	Addr. 0x17, bit 2	
Code	Function	
0	No internal pull-up	
1	Internal 300 µA pull-up current source active	

Table 52: Pull-Up Enable, Alarm Output ERR

Excessive Temperature Warning

Exceeding the temperature warning threshold T_w (corresponds to T_2 , refer to Temperature Sensor, page 19) can be signaled at pin ERR or used to shut down the line drivers (via mask EMASKO). The temperature warning is cleared when the temperature falls below $T_w - T_{hys}$.

Note: If the temperature shutdown threshold $T_{off} = T_w + \Delta T$ is exceeded, the line drivers are shut down independently of EMASKO. For ΔT refer to Elec. Char. E06.

Driver Shutdown

PDMODE Addr. 0x18, bit 6	
Code	Function
0	Driver shutdown terminates with the error event
1	Permanent driver shutdown until cycling power

Table 53: Driver Activation

Error Protocol

Out of the errors enabled by EMASKE both the first error (under ERR1) and last error (under ERR2) which occur after the iC-MSC is powered up are stored in the EEPROM.

The EEPROM also has a memory area in which all occurring errors can be stored (ERR3). Only the fact that

an error has occurred can be recorded, with no information as to the time and count of appearance of that error given. Error recording can be used to statistically evaluate the causes of system failure, for example.

ERR1 Addr. 0x20, bit 6:0	
ERR2 Addr. 0x22, bit 0; Addr. 0x21, bit 7:2	
ERR3 Addr. 0x23, bit 2:0; Addr. 0x22, bit 7:4	
Bit	Error Event
6:0	Assignment according to EMASKE
Code	Function
0	No event
1	Registered error event

Table 54: Error Protocol

REVERSE POLARITY PROTECTION

The line drivers in iC-MSC are protected against reverse polarity and short-circuiting. A defective or wrongly connected device cable cause damage neither to iC-MSC nor to the components protected against reverse polarity by VDDS and GNDS.

The following pins are also reverse polarity protected: PC, NC, PS, NS, PZ, NZ, ERR, VDD, GND and ACO

(as long as GNDS is only loaded relative to VDDS). The maximum voltage difference between the pins should not exceed 6 V (8 V for pin ERR).

Note: If iC-MSC detects reverse polarity on power up, the line drivers will not be enabled. If the state of reverse polarity is resolved, iC-MSC reboots from the EEPROM and enables the line drivers.

APPLICATION HINTS

Connecting MR sensor bridges for safety-related applications

For safety-related applications iC-MSC requires an external overvoltage protection of supply VDD (Zener diode with fuse, for instance) and external pull-down resistors at the inputs X3 to X6 towards GNDs (of up to 100 kΩ).

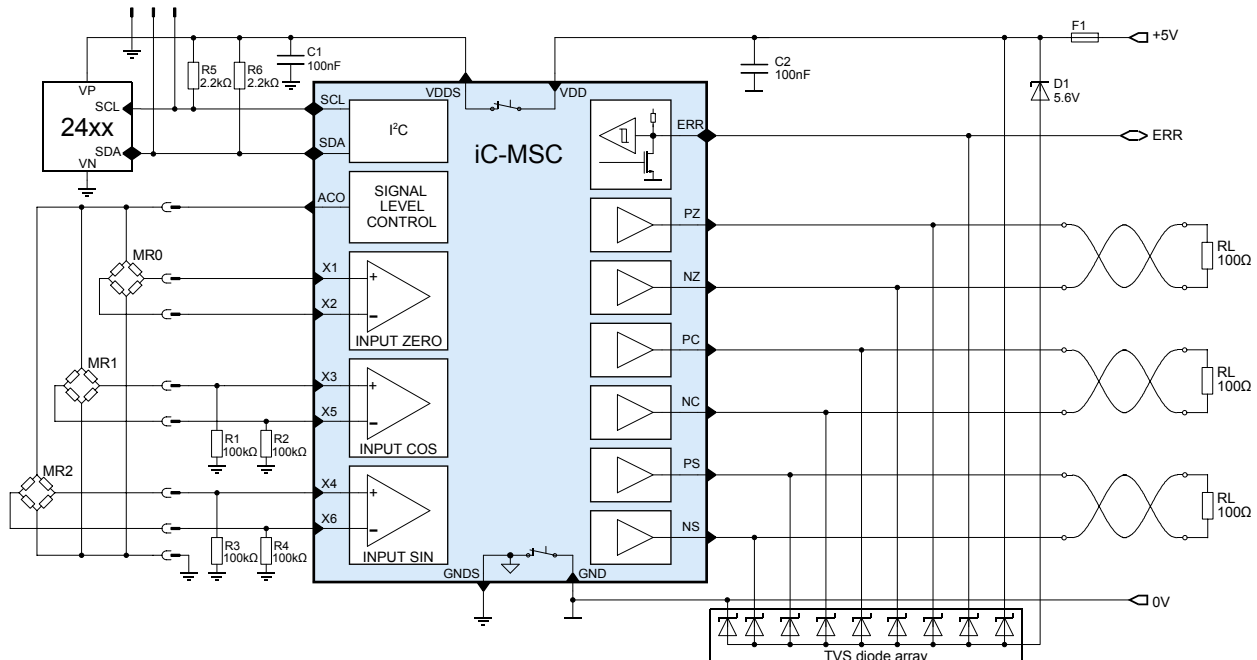

Figure 11: Example circuit for safety-related applications.

PLC Operation

There are PLCs with a remote sense supply which require more time for the voltage control to settle. At the same time the PLC inputs can have high-impedance resistances relative to an internal, negative supply voltage which define the input potential for open inputs.

In this instance iC-MSC’s reverse polarity protection feature can be activated as the outputs are tristate during the start phase and the resistances in the PLC determine the pin potential. During the start phase

neither the supply VDD nor the output pins, which are also monitored, must fall to below ground potential (pin GND), otherwise the device will not be configured and the outputs remain permanently set to tristate.

Note: In order to ensure that iC-MSC starts with the PLCs mentioned above pull-up resistors can be used in the encoder. Values of 100 kΩ are usually sufficient; it is, however, recommended that PLC specifications be specifically referred to here.

iC-MSC SIN/COS SIGNAL CONDITIONER WITH FAIL-SAFE 1 Vpp LINE DRIVER

preliminary



Rev A2, Page 34/35

REVISION HISTORY

Rel.	Rel. Date*	Chapter	Modification	Page
A1	2018-04-17	All	Initial release	

Rel.	Rel. Date*	Chapter	Modification	Page
A2	2018-08-15	PACKAGING INFORMATION	Footnote: value of bypass cap Package TSSOP20-TP: update of pinout, and dimensions added	4, 6
		ABSOLUTE MAXIMUM RATINGS	Item G001, G002: condition added Item G004, G005: items added	8
		ELECTRICAL CHARACTERISTICS	Items 102, 202: formula corrected Items 103, 203: conditions and limits Items 601, 602: conditions reduced	9
		BIAS CURRENT SOURCE AND TEMPERATURE SENSOR CALIBRATION	Measurement of IBN: note box updated Temperature sensor calibration: description updated Table 14: correction of formula, footnote updated	19
		SIGNAL LEVEL CONTROL and SIGNAL MONITORING	Table 41: min. range and note added Table 48: note added	29, 30
		ERROR MONITORING AND ALARM OUTPUT	Table 54: corrected to bits 6:0	32

iC-Haus expressly reserves the right to change its products and/or specifications. An Infoletter gives details as to any amendments and additions made to the relevant current specifications on our internet website www.ichaus.com/infoletter and is automatically generated and shall be sent to registered users by email. Copying – even as an excerpt – is only permitted with iC-Haus' approval in writing and precise reference to source.

The data specified is intended solely for the purpose of product description and shall represent the usual quality of the product. In case the specifications contain obvious mistakes e.g. in writing or calculation, iC-Haus reserves the right to correct the specification and no liability arises insofar that the specification was from a third party view obviously not reliable. There shall be no claims based on defects as to quality in cases of insignificant deviations from the specifications or in case of only minor impairment of usability.

No representations or warranties, either expressed or implied, of merchantability, fitness for a particular purpose or of any other nature are made hereunder with respect to information/specification or the products to which information refers and no guarantee with respect to compliance to the intended use is given. In particular, this also applies to the stated possible applications or areas of applications of the product.

iC-Haus products are not designed for and must not be used in connection with any applications where the failure of such products would reasonably be expected to result in significant personal injury or death (*Safety-Critical Applications*) without iC-Haus' specific written consent. Safety-Critical Applications include, without limitation, life support devices and systems. iC-Haus products are not designed nor intended for use in military or aerospace applications or environments or in automotive applications unless specifically designated for such use by iC-Haus.

iC-Haus conveys no patent, copyright, mask work right or other trade mark right to this product. iC-Haus assumes no liability for any patent and/or other trade mark rights of a third party resulting from processing or handling of the product and/or any other use of the product.

Software and its documentation is provided by iC-Haus GmbH or contributors "AS IS" and is subject to the ZVEI General Conditions for the Supply of Products and Services with iC-Haus amendments and the ZVEI Software clause with iC-Haus amendments (www.ichaus.com/EULA).

* Release Date format: YYYY-MM-DD

iC-MSC SIN/COS SIGNAL CONDITIONER WITH FAIL-SAFE 1 Vpp LINE DRIVER

preliminary



Rev A2, Page 35/35

ORDERING INFORMATION

Type	Package	Options	Order Designation
iC-MSC	TSSOP20-TP RoHS compliant	Thermal pad; Temperature range -40 °C to +125 °C	iC-MSC TSSOP20-TP
Evaluation Board			iC-MSC EVAL MSB1D

Please send your purchase orders to our order handling team:

Fax: +49 (0) 61 35 - 92 92 - 692

E-Mail: dispo@ichaus.com

For technical support, information about prices and terms of delivery please contact:

iC-Haus GmbH
Am Kuemmerling 18
D-55294 Bodenheim
GERMANY

Tel.: +49 (0) 61 35 - 92 92 - 0
Fax: +49 (0) 61 35 - 92 92 - 192
Web: <http://www.ichaus.com>
E-Mail: sales@ichaus.com

Appointed local distributors: http://www.ichaus.com/sales_partners