

iC-LSB

8-CHANNEL ACTIVE PHOTODIODE ARRAY



Rev C1, Page 1/7

FEATURES

- Monolithic array of independent photodiodes with excellent matching
- Compact photodiode size of $800\ \mu\text{m} \times 300\ \mu\text{m}$ enabling high-quality encoder scanning at reduced system dimensions
- Narrow track pitch of $0.42\ \text{mm}$ cuts down illumination efforts
- Enhanced EMI immunity due to on-chip pre-amplification
- Dark current compensation permits high temperature operation
- Open-collector outputs as highside current source
- Simple gain setting and current-to-voltage conversion by external load resistors
- Single supply operation from $4\ \text{V}$ to $5.5\ \text{V}$
- Low power consumption
- Space saving, RoHS compliant optoQFN and optoBGA packages
- Options: extended temperature range of -40 to $125\ ^\circ\text{C}$, customized COB modules, reticles and code discs

APPLICATIONS

- Optical position encoding from analog sine/cosine signals
- Incremental encoders with index signal

PACKAGES

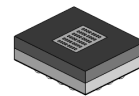

14-pin optoBGA
6.2mm x 5.2mm

BLOCK DIAGRAM

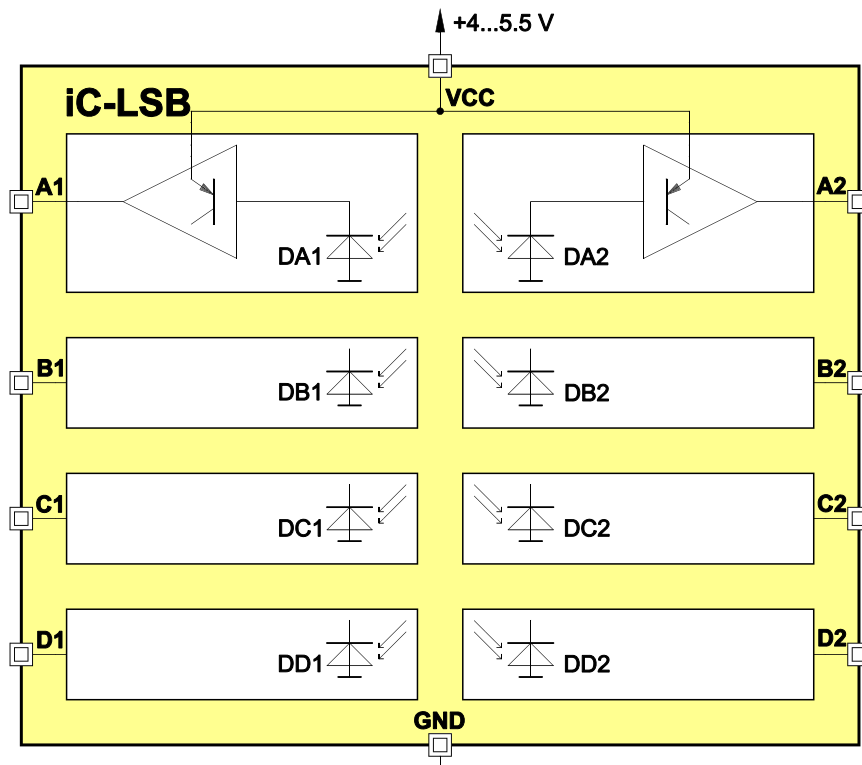

iC-LSB

8-CHANNEL ACTIVE PHOTODIODE ARRAY



Rev C1, Page 2/7

DESCRIPTION

The iC-LSB sensor array, coming with 8 independent channels, is a general purpose optoelectronic scanner made to suit a variety of encoding applications, such as rotary and linear encoders used for motion control, robotics, power tools etc.

The sensor array features monolithically integrated photodiodes with active areas of $800\ \mu\text{m} \times 300\ \mu\text{m}$ each in combination with fast on-chip photocurrent amplifiers, enabling an analog output at reasonable signal strength to the circuit board.

The highside current source output construction

avoids a ground referenced signal and permits the subsequent electronics to adjust the gain. In its simplest form this is done by load resistors, for instance.

The spectral sensitivity range includes visible to near infrared light, with the maximum sensitivity being close to a wavelength of 700 nm.

Output currents of up to $50\ \mu\text{A}$ are supplied under low light conditions, for instance when illuminated at only $3\ \mu\text{W}/\text{mm}^2$ by an 850 nm LED. The photocurrent gain is 46 dB typically.

PACKAGES

PAD LAYOUT

Chip size 2.80 mm x 1.96 mm

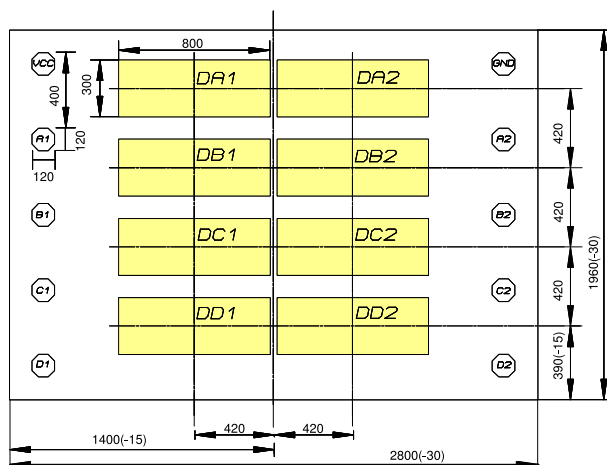

PAD FUNCTIONS

No. Name Function

- | | | |
|----|-----|--------------------------------|
| 1 | VCC | +4...5.5 V Supply Voltage |
| 2 | A1 | Highside Current Source Output |
| 3 | B1 | Highside Current Source Output |
| 4 | C1 | Highside Current Source Output |
| 5 | D1 | Highside Current Source Output |
| 6 | D2 | Highside Current Source Output |
| 7 | C2 | Highside Current Source Output |
| 8 | B2 | Highside Current Source Output |
| 9 | A2 | Highside Current Source Output |
| 10 | GND | Ground |

PIN CONFIGURATION

oBGA LS2C (6.2 mm x 5.2 mm)

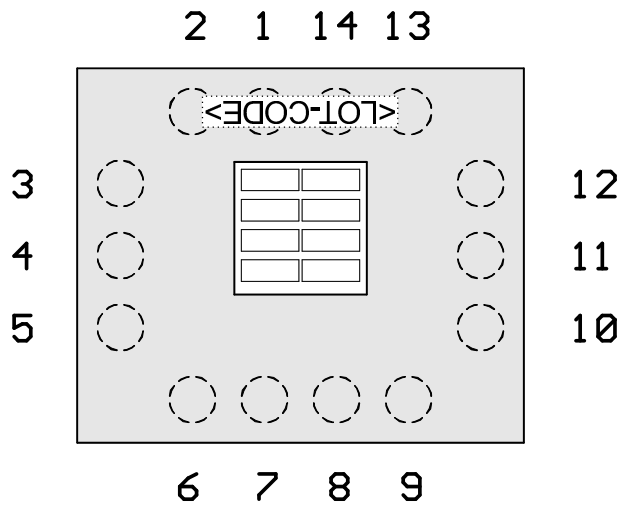

PIN FUNCTIONS

No. Name Function

1	VCC	+4...5.5 V Supply Voltage
2	A1	Highside Current Source Output
3	B1	Highside Current Source Output
4	C1	Highside Current Source Output
5	D1	Highside Current Source Output
6...9	n.c.	
10	D2	Highside Current Source Output
11	C2	Highside Current Source Output
12	B2	Highside Current Source Output
13	A2	Highside Current Source Output
14	GND	Ground

Pin numbers marked n.c. are not in use. For dimensional specifications refer to the relevant package data sheets, available separately. IC top markings, such as <LOT CODE>, indicate the orientation of the device.

ABSOLUTE MAXIMUM RATINGS

These ratings do not imply operating conditions; functional operation is not guaranteed. Beyond these ratings device damage may occur.

Item No.	Symbol	Parameter	Conditions	Limits		Unit
				Min.	Max.	
G001	VCC	Voltage at VCC		-0.3	6	V
G002	I(VCC)	Current in VCC		-20	20	mA
G003	V()	Pin Voltage, all signal outputs		-0.3	VCC+0.3	V
G004	I()	Pin Current, all signal outputs		-20	20	mA
G005	Vd()	ESD Susceptibility, all pins	HBM, 100 pF discharged through 1.5 k Ω		2	kV
G006	Tj	Junction Temperature		-40	150	$^{\circ}$ C
G007	Ts	Chip Storage Temperature		-40	150	$^{\circ}$ C

THERMAL DATA

Item No.	Symbol	Parameter	Conditions	Limits			Unit
				Min.	Typ.	Max.	
T01	Ta	Operating Ambient Temperature Range	package oBGA LS2C (extended temperature range on request)	-20		90	$^{\circ}$ C
T02	Ts	Storage Temperature Range	package oBGA LS2C	-30		110	$^{\circ}$ C
T03	Tpk	Soldering Peak Temperature	package oBGA LS2C tpk < 20 s, convection reflow tpk < 20 s, vapor phase soldering TOL (time on label) 8 h; Please refer to customer information file No. 7 for details.			245 230	$^{\circ}$ C $^{\circ}$ C

All voltages are referenced to ground unless otherwise stated.

All currents flowing into the device pins are positive; all currents flowing out of the device pins are negative.

ELECTRICAL CHARACTERISTICS

Operating conditions: $V_{CC} = 4...5.5\text{ V}$, $T_j = -40...125\text{ }^\circ\text{C}$, unless otherwise stated

Item No.	Symbol	Parameter	Conditions				Unit
				Min.	Typ.	Max.	
Total Device							
001	VCC	Permissible Supply Voltage		4		5.5	V
002	I(VCC)	Supply Current in VCC, dark	$E() = 0$ $T_j = 27\text{ }^\circ\text{C}$		1.0	2	mA mA
003	I(VCC)	Supply Current in VCC	$\lambda_{LED} = \lambda_{pk}$, $E() = 0.1\text{ mW/cm}^2$ $T_j = 27\text{ }^\circ\text{C}$		1.5	4	mA mA
004	Vc(hi)	Clamp-Voltage hi at all pins	$I() = 4\text{ mA}$			11	V
005	Vc(lo)	Clamp-Voltage lo at all pins	$I() = -4\text{ mA}$	-1.2		-0.3	V
Photosensors							
101	E(mx)	Permissible Irradiance	$\lambda_{LED} = \lambda_{pk}$			0.2	mW/ cm ²
102	Aph()	Radiant Sensitive Area	0.8 mm x 0.3 mm per sensor		0.24		mm ²
103	λ_{ar}	Spectral Application Range	$Se(\lambda_{ar}) = 0.25 \times S(\lambda)_{max}$ see Figure 1	400		950	nm
104	λ_{pk}	Peak Sensitivity Wavelength	see Figure 1		680		nm
105	S(λ)	Spectral Sensitivity	$\lambda_{LED} = \lambda_{pk}$		0.45		A/W
Photocurrent Amplifiers							
201	Iph()	Permissible Photocurrent Operating Range	per sensor	0		200	nA
202	$\eta()r$	Photo Sensitivity (light-to-voltage conversion ratio)	$\lambda_{LED} = 740\text{ nm}$	60		120	A/W
203	CR()	Photocurrent Gain	$CR() = I_{out}() / I_{ph}()$	150	200	250	
204	fc(hi)	Cut-off Frequency (-3 dB)		150	200		kHz
205	$\Delta I_{out}(m)$	Channel Matching	deviation from mean value	-15		+15	%
206	$\Delta I_{out}(m)$	Channel Cross Talk	only one photosensor illuminated at the same time		0		%
Current Source Outputs							
301	Vout()	Permissible Output Voltage (Operating Range)		1		VCC - 1.5	V
302	Iout()	Permissible Output Current	$V_{out}() = 1\text{ V} \dots V_{CC} - 1.5\text{ V}$ $V_{CC} = 4.5...5.5\text{ V}$, $V_{out}() = 1\text{ V} \dots V_{CC} - 2\text{ V}$	-50 -200			μA μA
303	tr(), tf()	Output Current Rise/Fall Time	$I_{ph}: 0 \rightarrow 100\text{ nA}$, 1T settling (63%); $V_{out}() = \text{constant}$ $C_L = 30\text{ pF}$, $R_L() = 10\text{ k}\Omega$		0.7 0.8		μs μs
304	Iout(0)	Output Dark Current		-0.6		+0.6	μA

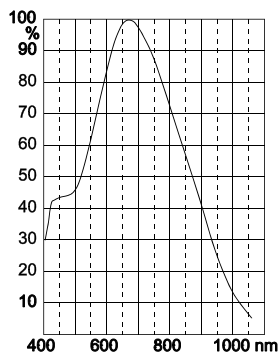

Figure 1: Relative spectral response

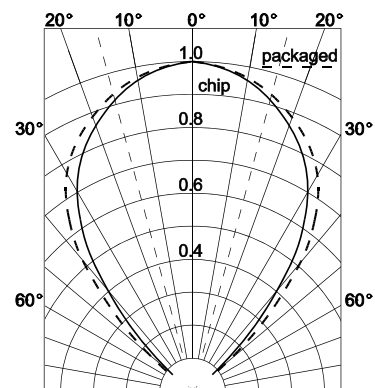

Figure 2: Typical directional characteristics

APPLICATION CIRCUITS

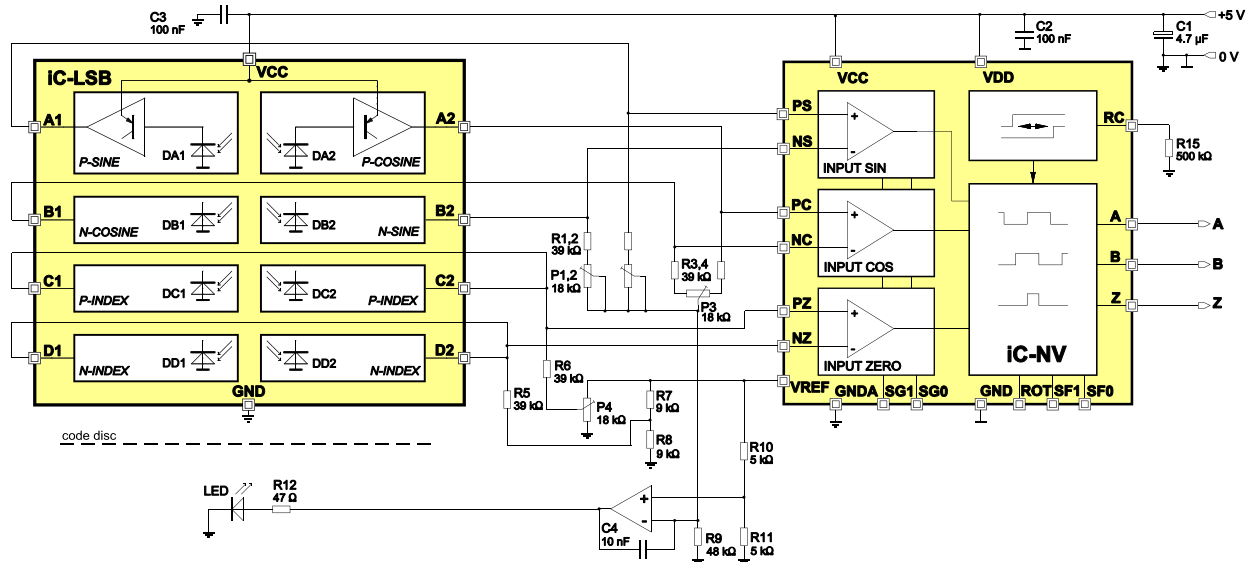

Figure 3: Optical encoder application example. Here, the sine-to-digital converter iC-NV is employed to output spike-free encoder quadrature signals featuring a minimum transition distance.

iC-Haus expressly reserves the right to change its products and/or specifications. An Infoletter gives details as to any amendments and additions made to the relevant current specifications on our internet website www.ichaus.de/infoletter; this letter is generated automatically and shall be sent to registered users by email.

Copying – even as an excerpt – is only permitted with iC-Haus approval in writing and precise reference to source.

iC-Haus does not warrant the accuracy, completeness or timeliness of the specification on this site and does not assume liability for any errors or omissions in the materials. The data specified is intended solely for the purpose of product description. No representations or warranties, either express or implied, of merchantability, fitness for a particular purpose or of any other nature are made hereunder with respect to information/specification or the products to which information refers and no guarantee with respect to compliance to the intended use is given. In particular, this also applies to the stated possible applications or areas of applications of the product.

iC-Haus conveys no patent, copyright, mask work right or other trade mark right to this product. iC-Haus assumes no liability for any patent and/or other trade mark rights of a third party resulting from processing or handling of the product and/or any other use of the product.

As a general rule our developments, IPs, principle circuitry and range of Integrated Circuits are suitable and specifically designed for appropriate use in technical applications, such as in devices, systems and any kind of technical equipment, in so far as they do not infringe existing patent rights. In principle the range of use is limitless in a technical sense and refers to the products listed in the inventory of goods compiled for the 2008 and following export trade statistics issued annually by the Bureau of Statistics in Wiesbaden, for example, or to any product in the product catalogue published for the 2007 and following exhibitions in Hanover (Hannover-Messe).

We understand suitable application of our published designs to be state-of-the-art technology which can no longer be classed as inventive under the stipulations of patent law. Our explicit application notes are to be treated only as mere examples of the many possible and extremely advantageous uses our products can be put to.

iC-LSB

8-CHANNEL ACTIVE PHOTODIODE ARRAY



Rev C1, Page 7/7

ORDERING INFORMATION

Type	Package	Options	Order Designation
iC-LSB	-		iC-LSB chip
	14-pin optoBGA 6.2 mm x 5.2 mm	glass lid	iC-LSB oBGA LS2C
	14-pin optoBGA 6.2 mm x 5.2 mm	on-chip reticle	iC-LSB oBGA LS2C-LSBxR

For technical support, information about prices and terms of delivery please contact:

iC-Haus GmbH
Am Kuemmerling 18
D-55294 Bodenheim
GERMANY

Tel.: +49 (61 35) 92 92-0
Fax: +49 (61 35) 92 92-192
Web: <http://www.ichaus.com>
E-Mail: sales@ichaus.com

Appointed local distributors: http://www.ichaus.com/sales_partners