

FEATURES

- ◆ Wide input voltage range of +4 to +36 V
- ◆ Reverse polarity protection up to -36 V with autarky function
- ◆ Universal buck/boost converter with high efficiency
- ◆ Two back-end, adjustable linear regulators (1.5 V to 5.5 V) with a total of up to 300 mA of output current and a separate output voltage monitor
- ◆ Low residual ripple with small capacitors in the μF range
- ◆ Separate enable inputs for the linear regulators
- ◆ Two switched linear regulator outputs
- ◆ Integrated switching transistors and flyback diodes
- ◆ Converter cut-off current can be set by an external resistor
- ◆ Integrated 3 MHz oscillator with no external components
- ◆ Active noise spectrum reduction
- ◆ Error messaging with overtemperature, overvoltage, and undervoltage at the current-limited open-collector output
- ◆ Wide temperature range of $-40\text{ }^{\circ}\text{C}$ to $105\text{ }^{\circ}\text{C}$
- ◆ Protective circuitry against ESD
- ◆ Space saving 24-pin QFN package

APPLICATIONS

- ◆ Dual voltage supply by buck/boost converters with adjustable, back-end linear regulators
- ◆ Power management for laser, encoder, and automotive applications

PACKAGES

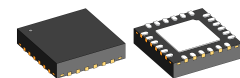

QFN24 4 mm x 4 mm
(RoHS compliant)

BLOCK DIAGRAM

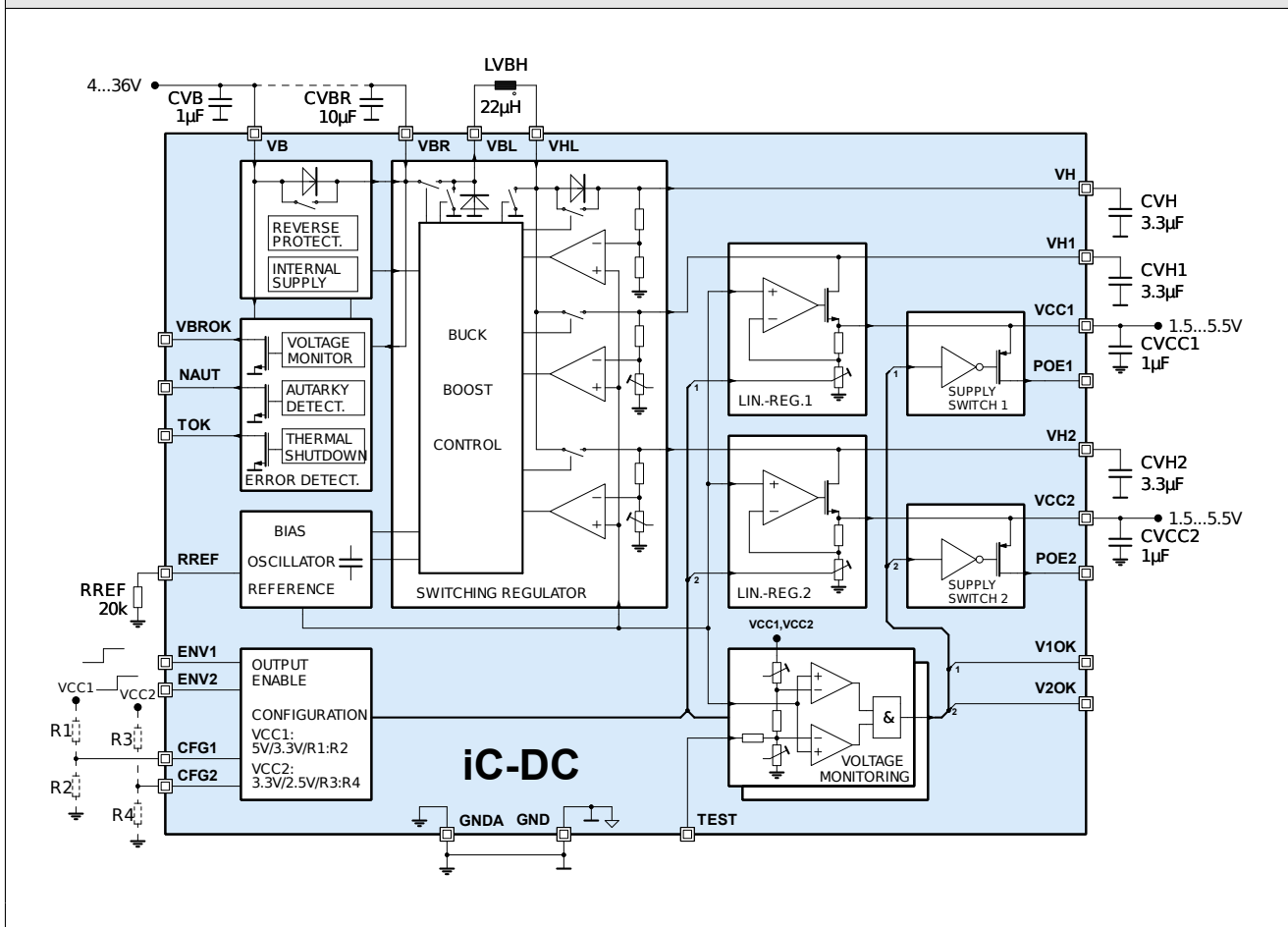

DESCRIPTION

iC-DC is a monolithic switching converter with two back-end linear regulators. The output voltages of the two linear regulators can be individually pin-configured within a range of 1.5 to 5.5 V. The switching converter supplies up to 300 mA which can be drawn from the two linear regulators in the ratio required.

The intermediate voltages of the two on-chip linear regulators are adjusted to minimize their drop-out voltages. These are approximately 400 mV above the set linear regulator output voltages.

The high efficiency of the buck/boost converter for an input voltage range of +4 V to +36 V makes iC-DC suitable for industrial applications. Using very few external components, a DC/DC power pack can be created with a stabilized supply voltage and minimum power dissipation.

iC-DC is ideal for sensor applications thanks to its minimal power loss, few components, and stabilized supply. Switching transistors, flyback diodes, and an oscillator are integrated in the device so that the only external elements needed are an inductor, the back-up capacitors, and a reference resistor.

The back-end linear regulators have a very low residual ripple with comparatively small filter capacitors in the single-digit μF range.

By using two independent regulators voltages can be decoupled from sensitive analog circuits and driver devices, for example.

The chip temperature, input voltage, and integrated reverse polarity protection are monitored and errors signaled by current-limited open-collector outputs. With overtemperature the switching converter is disabled to reduce the chip's power dissipation.

The linear regulator output voltages are monitored and once having reached the steady state they are also switched to outputs POE1 and POE2. The output voltages of the two linear regulators VCC1 and VCC2 can be switched on and off by two separate inputs.

The device's standby function can be activated to minimize the current consumption.

CONTENTS

PACKAGING INFORMATION	4	REVERSE POLARITY PROTECTION	14
PIN CONFIGURATION		ERROR EVALUATION	15
QFN24-4x4		Supply voltage monitor	15
(topview)	4	Output voltage monitor	15
PACKAGE DIMENSIONS	5	Output voltage monitor self-test	15
ABSOLUTE MAXIMUM RATINGS	6	Temperature monitor	15
THERMAL DATA	6	AUTARKY FUNCTION	15
ELECTRICAL CHARACTERISTICS	7	DESCRIPTION OF THE APPLICATION	16
DESCRIPTION OF FUNCTIONS	11	Selecting the coil	16
Charge/discharge phase	11	Selecting the capacitors	16
Intermittent flow / continuous flow	12	Printed circuit board layout	16
Startup behavior	12	EXAMPLE APPLICATION	17
Standby	12	DESIGN REVIEW: Notes On Chip Functions	18
LINEAR REGULATORS VCC1 AND VCC2	13	REVISION HISTORY	18
Switched output voltages	13		
Voltage monitor self-test	13		
Current carrying capacity	13		

PACKAGING INFORMATION

PIN CONFIGURATION

QFN24-4x4

(topview)

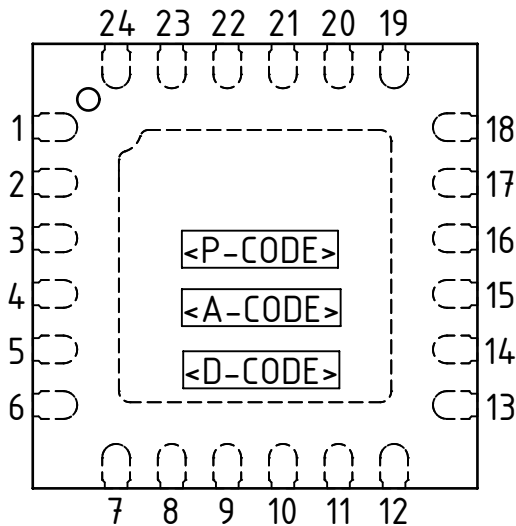

PIN FUNCTIONS

No.	Name	Function
1	RREF	Reference Resistor
2	GND A	Analog Ground
3	CFG1	VCC1 Configuration 3.3/5.0 V or 1.5 V to 5.5 V with ext. R Divider
4	CFG2	VCC2 Configuration 2.5/3.3 V or 1.5 V to 5.5 V with ext. R Divider
5	TEST	Test Input
6	POE2	Power Output Enable VCC2 Voltage
7	V2OK	Error Output VCC2 Voltage
8	VCC2	1.5 V to 5.5 V Lin. Regulator Output 2
9	VH2	Intermediate Voltage 2 for VCC2 Regulator
10	VH1	Intermediate Voltage 1 for VCC1 Regulator
11	VCC1	1.5 V to 5.5 V Lin. Regulator Output 1
12	V1OK	Error Output VCC1 Voltage
13	POE1	Power Output Enable VCC1 Voltage
14	VH	Intermediate Voltage
15	VHL	Inductor Terminal VH
16	GND	Power Ground
17	VBL	Inductor Terminal VB
18	VBR	Reverse Protected Supply Voltage
19	VB	+4 V to +36 V Supply Voltage
20	ENV1	VCC1 Linear Regulator Activation
21	ENV2	VCC2 Linear Regulator Activation
22	VBROK	Error Output Supply Voltage
23	TOK	Error Output Overtemperature
24	NAUT	Error Output Autarky
	BP	Backside Paddle (Thermal Pad)

IC top marking: <P-CODE> = product code, <A-CODE> = assembly code (subject to changes), <D-CODE> = date code (subject to changes); To improve the heat dissipation connect the backside paddle to an extended copper area connected to GND. Avoid any current flow across the paddle. The heat distribution can be supported by connecting further PCB layers using *thermal vias*. If those need to be placed below the paddle, prefer blind vias. GND A should also be directly connected to neutral point GND. Ground loops should be avoided.

PACKAGE DIMENSIONS

RECOMMENDED PCB-FOOTPRINT

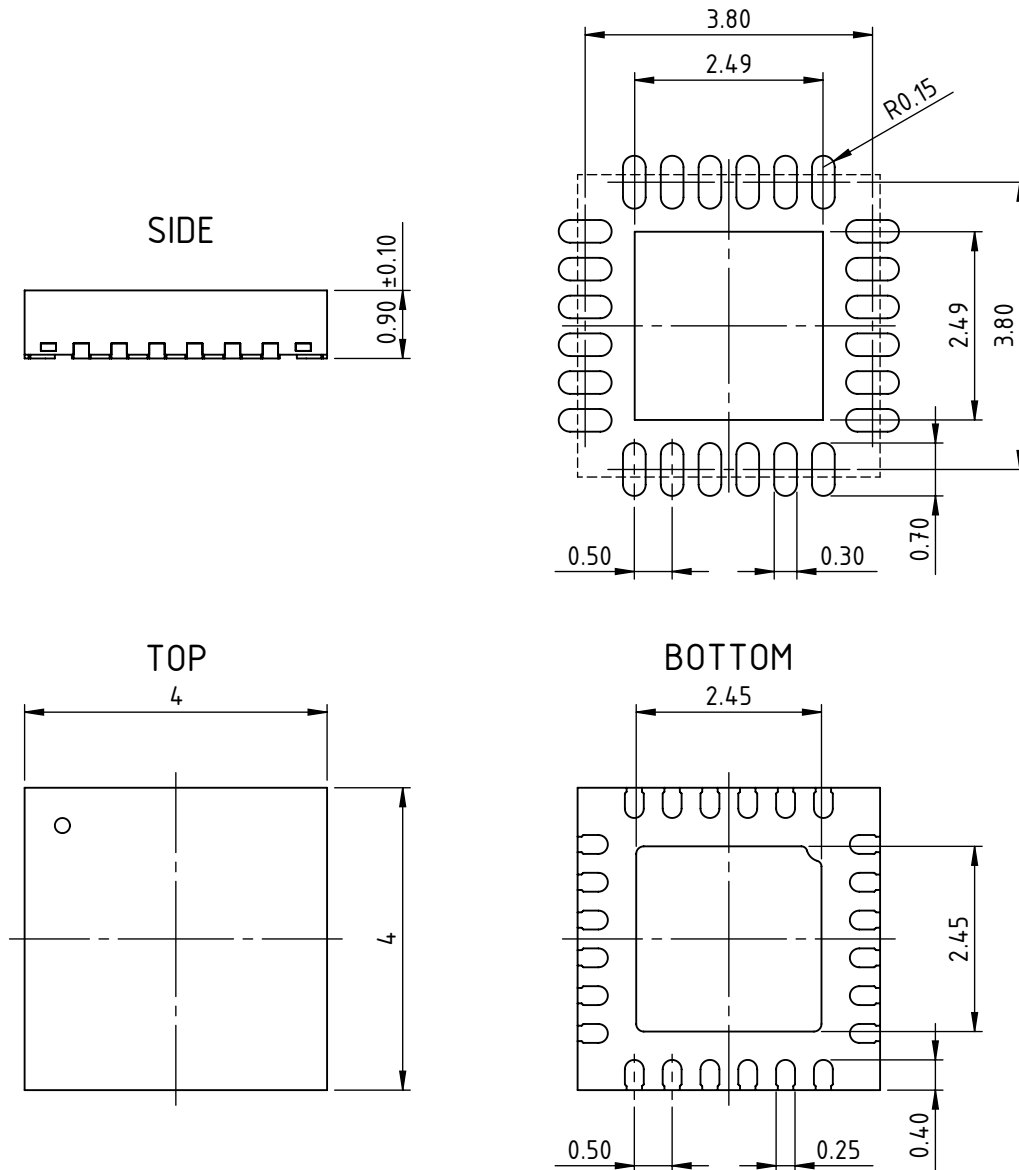

All dimensions given in mm.
Tolerances of form and position according to JEDEC MO-220.

ABSOLUTE MAXIMUM RATINGS

Maximum ratings do not constitute permissible operating conditions; functionality is not guaranteed. Exceeding the maximum ratings can damage the device.

Item No.	Symbol	Parameter	Conditions	Limits		Unit
				Min.	Max.	
G001	V()	Voltage at VB		-38.5	42	V
G002	V()	Voltage at VBR, VBL, ENV1, ENV2		-0.3	42	V
G003	V()	Voltage at VHL, VH, VBROK, NAUT, TOK, TEST		-0.3	8.4	V
G004	V()	Voltage at VH1, VH2		-0.3	6.4	V
G005	V()	Voltage at VCC1, VCC2, V1OK, V2OK, CFG1, CFG2, POE1, POE2, RREF, GNDA		-0.3	5.6	V
G006	I(VB)	Current in VB		-50	800	mA
G007	I(VBR)	Current in VBR		-50	800	mA
G008	I(VBL)	Current in VBL		-800	50	mA
G009	I(VHL)	Current in VHL		-50	800	mA
G010	I()	Current in VH, VH1, VH2, VCC1, VCC2		-500	20	mA
G011	I()	Current in CFG1, CFG2, ENV1, ENV2, V1OK, V2OK, VBROK, NAUT, TOK, POE1, POE2, RREF, TEST, GNDA		-20	20	mA
G012	Vd()	ESD Susceptibility at all pins	HBM, 100 pF discharged through 1.5 kΩ		2	kV
G013	Tj	Chip-Temperature		-40	150	°C
G014	Ts	Storage Temperature Range		-40	150	°C

THERMAL DATA

Operating conditions: VB = +4 V to +36 V

Item No.	Symbol	Parameter	Conditions	Limits			Unit
				Min.	Typ.	Max.	
T01	Ta	Operating Ambient Temperature Range		-40		105	°C
T02	Rthja	Thermal Resistance Chip to Ambient QFN24	Surface mounted, Thermal-Pad soldered to approx. 2 cm ² copper area on the PCB		30	40	K/W

All voltages are referenced to ground (pin GND: power ground) unless otherwise stated.

All currents flowing into the device pins are positive; all currents flowing out of the device pins are negative.

ELECTRICAL CHARACTERISTICS

Operating conditions: $V_B = +4\text{ V to }+36\text{ V}$, $R_{REF} = 20\text{ k}\Omega \pm 1\%$, $T_j = -40^\circ\text{C to }+125^\circ\text{C}$, reference is GND (GNDA = GND), unless otherwise stated.

Item No.	Symbol	Parameter	Conditions				Unit
				Min.	Typ.	Max.	
Total Device							
001	V_B	Permissible Supply Voltage		4		36	V
002	$I()$	Supply Current in V_B	ENV1 = lo, ENV2 = lo, standby	20	100	400	μA
003	$I()$	Supply Current in V_B	only one Linear Regulator active, no load current, no external voltage divider $V_B = 24\text{ V}$ $V_B = 12\text{ V}$ $V_B = 4\text{ V}$	1.5 2.5 10	3 5.5 22	8 15 60	mA mA mA
004	$I()$	Supply Current in V_B	both Linear Regulators active, no load current, no external voltage divider $V_B = 24\text{ V}$ $V_B = 12\text{ V}$ $V_B = 4\text{ V}$	2 3 12	4 7 25	10 20 70	mA mA mA
007	$I_{pd}()$	Pull-Down Current in ENV1, ENV2	$V() = 2\dots36\text{ V}$	15		150	μA
009	$V_t(\text{hi})$	Input Threshold Voltage hi at ENV1, ENV2				2	V
010	$V_t(\text{lo})$	Input Threshold Voltage lo at ENV1, ENV2		0.8			V
011	$V_t(\text{hys})$	Input Hysteresis at ENV1, ENV2	$V_t(\text{hys}) = V_t(\text{hi}) - V_t(\text{lo})$	100	200	400	mV
012	$V_c(\text{lo})$	Clamp Voltage lo at all pins with exception of V_B	versus GND, $I() = -10\text{ mA}$	-1.4		-0.3	V
013	$V_c(\text{lo})$	Clamp Voltage lo at V_B	versus GND, $I() = -10\text{ mA}$	-60		-38.5	V
014	$V_c(\text{hi})$	Clamp Voltage hi at V_B , VBR, VBL, ENV1, ENV2	versus GND, $I() = 2\text{ mA}$	42		60	V
015	$V_c(\text{hi})$	Clamp Voltage hi at VBROK, NAUT, TOK, TEST	versus GND, $I() = 1\text{ mA}$	9		18	V
016	$V_c(\text{hi})$	Clamp Voltage hi at VH	versus GND, $I() = 5\text{ mA}$	8.3		18	V
017	$V_c(\text{hi})$	Clamp Voltage hi at VH1, VH2	versus GND, $I() = 10\text{ mA}$	6.2		18	V
018	$V_c(\text{hi})$	Clamp Voltage hi at VCC1, VCC2, POE1, POE2, CFG1, CFG2	versus GND, $I() = 10\text{ mA}$	5.6		18	V
019	$V_c(\text{hi})$	Clamp Voltage hi at GNDA, RREF	versus GND, $I() = 10\text{ mA}$	2.5		18	V
020	$V_c(\text{hi})$	Clamp Voltage hi at V1OK, V2OK	V1OK versus VCC1, V2OK versus VCC2, $I() = 2\text{ mA}$	0.3		1.4	V
021	$V_c(\text{hi})$	Clamp Voltage hi at VHL	versus VH, $I() = 10\text{ mA}$	0.3		1.4	V
Reverse Polarity Protection V_B, VBR and Autarky Detection NAUT							
101	$V_s(\text{hi})$	Saturation Voltage hi at VBR	$V_s(\text{VBR})_{\text{hi}} = V_B - V(\text{VBR})$, $I(\text{VBR}) = -100\text{ mA}$		0.3	0.7	V
103	$I_{zu}()$	Maximum Permissible Current hi from VBR at Startup	$V(\text{VBR}) = 0\dots3\text{ V}$, V_B increasing	-5		0	mA
104	$I_{\text{max}}()$	Maximum Current from VBR	$V(\text{VBR}) = 2\text{ V}\dots V_B - 0.6\text{ V}$	-600		-80	mA
105	$I_{\text{max}}()$	Maximum Current from VBR	$V(\text{VBR}) = 0\text{ V}$	-250		-10	mA
108	$I_r()$	Leakage Current from V_B at Autarky	$V_{BR} > V_B + 50\text{ mV}$	-0.5		0	mA
109	$d(\text{V}_B, \text{VBR})$	Voltage Difference for Autarky	V_{BR} versus V_B ; NAUT = lo	25	12.5	0	mV
110	$I_{r, \text{max}}()$	Maximum Current from V_B	$V_B < V_{BR} < V_B + 50\text{ mV}$	-10	-4	0	mA
111	$I_r()$	Reverse Current from V_B	$-36\text{ V} < V_B < \text{GND}$	-1		0	mA
112	$V_s(\text{lo})$	Saturation Voltage lo at NAUT	$I(\text{NAUT}) = 5\text{ mA}$, NAUT = lo			0.4	V
113	$I_{sc}(\text{lo})$	Short-Circuit Current lo in NAUT	$V(\text{NAUT}) = 2\dots8\text{ V}$, NAUT = lo		10	20	mA
114	$I_{lk}()$	Leakage Current in NAUT	$V(\text{NAUT}) = 0\dots8\text{ V}$, NAUT = hi	-10		10	μA
Voltage Monitoring VBR and Error Detection VBROK							
201	$V_{t1}(\text{hi})$	Lower Turn-on Threshold VBR	V_{BR} increasing, VBROK: lo \rightarrow open		3.75	3.95	V
202	$V_{t1}(\text{lo})$	Lower Turn-off Threshold VBR	V_{BR} decreasing, VBROK: open \rightarrow lo	2.8	3.15		V

ELECTRICAL CHARACTERISTICS

Operating conditions: $V_B = +4\text{ V to }+36\text{ V}$, $R_{REF} = 20\text{ k}\Omega \pm 1\%$, $T_J = -40^\circ\text{C to }+125^\circ\text{C}$, reference is GND (GNDA = GND), unless otherwise stated.

Item No.	Symbol	Parameter	Conditions	Min.	Typ.	Max.	Unit
203	Vt1()hys	Hysteresis VBR	$V_{t1}()_{hys} = V_{t1}()_{hi} - V_{t1}()_{lo}$	300	600		mV
204	Vt2()hi	Overvoltage Detection at VBR	VBR increasing, VBROK: open \rightarrow lo		40.4	42	V
205	Vt2()lo	Reset Overvoltage Detection at VBR	VBR decreasing, VBROK: lo \rightarrow open	35	37.6		V
206	Vt2()hys	Hysteresis VBR	$V_{t2}()_{hys} = V_{t2}()_{hi} - V_{t2}()_{lo}$	1	2.8	4	V
210	Vs()lo	Saturation Voltage lo at VBROK	$I(VBROK) = 5\text{ mA}$, $VBROK = lo$			0.4	V
211	Isc()lo	Short-Circuit Current lo in VBROK	$V(VBROK) = 2..8\text{ V}$, $VBROK = lo$			50	mA
212	Ilk()	Leakage Current in VBROK	$V(VBROK) = 0..8\text{ V}$, $VBROK = hi$	-10		10	μA
213	V(VBR)	Minimal Supply Voltage for VBROK Function	$I(VBROK) = 5\text{ mA}$, $VBROK = lo$, $V_s(VBROK)_{lo} < 0.4\text{ V}$	3.3			V
Switching Regulator VH, VH1, VH2							
305	V()	Voltage at VH	LVBH = $22\text{ }\mu\text{H} \pm 20\%$, $R_i(LVBH) < 1.1\text{ }\Omega$, CVH = $1\text{ }\mu\text{F}$; $V_B \leq 5\text{ V}$, $I(VH) = -50\text{ mA}$, $V_B > 5\text{ V}$, $I(VH) = -100\text{ mA}$, $V_B \geq 12\text{ V}$, $I(VH) = -200\text{ mA}$, $V_B \geq 24\text{ V}$, $I(VH) = -300\text{ mA}$	7 7.25 7.25 7.25	7.75 7.75 7.75 7.75	8 8 8 8	V V V V
307	CVH	Required Capacitor at VH	tolerance $\pm 30\%$	1	4.7		μF
308	RiVH	Permissible Internal Resistance of Capacitor at VH				1	Ω
309	V()	Voltage at VH1	versus VCC1, CVH1 = $1\text{ }\mu\text{F}$, $V_B \leq 5\text{ V}$, $I(VH1) = -50\text{ mA}$, $V_B > 5\text{ V}$, $I(VH1) = -100\text{ mA}$, $V_B \geq 12\text{ V}$, $I(VH1) = -200\text{ mA}$, $V_B \geq 24\text{ V}$, $I(VH1) = -300\text{ mA}$	300	400	600	mV
311	CVH1	Required Capacitor at VH1	tolerance $\pm 30\%$	2.2	10		μF
312	RiCVH1	Permissible Internal Resistance of Capacitor at VH1				1	Ω
313	V()	Voltage at VH2	versus VCC2, CVH2 = $1\text{ }\mu\text{F}$, $V_B \leq 5\text{ V}$, $I(VH2) = -50\text{ mA}$, $V_B > 5\text{ V}$, $I(VH2) = -100\text{ mA}$, $V_B \geq 12\text{ V}$, $I(VH2) = -200\text{ mA}$, $V_B \geq 24\text{ V}$, $I(VH2) = -300\text{ mA}$	300	400	600	mV
315	CVH2	Required Capacitor at VH2	tolerance $\pm 30\%$	2.2	10		μF
316	RiCVH2	Permissible Internal Resistance of Capacitor at VH2				1	Ω
330	η_{VH}	Efficiency of Switching Converter VH	$V_B = 4\text{ V}$, $V(VH) > 7\text{ V}$, $V_B = VBR$, $VH1 > VCC1 + 800\text{ mV}$, $VH2 > VCC2 + 800\text{ mV}$	70			%
331	η_{VH}	Efficiency of Switching Converter VH	$V_B = 6.5\text{ V}$, $V(VH) > 7\text{ V}$, $V_B = VBR$, $VH1 > VCC1 + 800\text{ mV}$, $VH2 > VCC2 + 800\text{ mV}$	80			%
332	η_{VH1}	Efficiency of Switching Converter VH1	$V_B = 4\text{ V}$, $V(VH) > 8.1\text{ V}$, $V_B = VBR$, ENV1 = hi, ENV2 = lo	70			%
333	η_{VH1}	Efficiency of Switching Converter VH1		80			%
334	η_{VH2}	Efficiency of Switching Converter VH2	$V_B = 4\text{ V}$, $V(VH) > 8.1\text{ V}$, $V_B = VBR$, ENV1 = lo, ENV2 = hi	70			%
335	η_{VH2}	Efficiency of Switching Converter VH2	$V_B = 6.5\text{ V}$, $V(VH) > 8.1\text{ V}$, $V_B = VBR$, ENV1 = lo, ENV2 = hi	80			%
Bias, Oscillator and Reference RREF							
401	V(RREF)	Voltage at RREF	resistor RREF = $20\text{ k}\Omega \pm 1\%$, resistor RREF versus GNDA	1.16	1.24	1.32	V
402	R(RREF)	Permissible Resistor at RREF	$\pm 1\%$	19.6		34	$\text{k}\Omega$
403	Isc(RREF)	Short-Circuit Current lo in RREF	$V(RREF) = 0\text{ V}$	-3		-0.5	mA

ELECTRICAL CHARACTERISTICS

Operating conditions: $V_B = +4\text{ V to }+36\text{ V}$, $R_{REF} = 20\text{ k}\Omega \pm 1\%$, $T_J = -40^\circ\text{C to }+125^\circ\text{C}$, reference is GND (GNDA = GND), unless otherwise stated.

Item No.	Symbol	Parameter	Conditions	Min.	Typ.	Max.	Unit
404	f _{os}	Oscillator Frequency	resistor $R_{REF} = 20\text{ k}\Omega \pm 1\%$, resistor R_{REF} versus GNDA	1.8		7	MHz
Linear Regulator VCC1							
501	$V_{CC1_{nom,hi}}$	Output Voltage	CFG1 = VCC1; $V_B < 5\text{ V}$, $I(V_{CC1}) = -60\text{...}10\text{ mA}$, $V_B \geq 5\text{ V}$, $I(V_{CC1}) = -100\text{...}10\text{ mA}$, $V_B \geq 6.5\text{ V}$, $I(V_{CC1}) = -150\text{...}10\text{ mA}$, $V_B \geq 12\text{ V}$, $I(V_{CC1}) = -200\text{...}10\text{ mA}$, $V_B \geq 24\text{ V}$, $I(V_{CC1}) = -250\text{...}10\text{ mA}$	4.75	5	5.25	V
502	$V_{CC1_{nom,lo}}$	Output Voltage	CFG1 = GNDA; $V_B < 5\text{ V}$, $I(V_{CC1}) = -100\text{...}10\text{ mA}$, $V_B \geq 5\text{ V}$, $I(V_{CC1}) = -150\text{...}10\text{ mA}$, $V_B \geq 6.5\text{ V}$, $I(V_{CC1}) = -200\text{...}10\text{ mA}$, $V_B \geq 16\text{ V}$, $I(V_{CC1}) = -300\text{...}10\text{ mA}$, $V_B \geq 24\text{ V}$, $I(V_{CC1}) = -350\text{...}10\text{ mA}$,	3.135	3.3	3.465	V
503	$V_r(CFG1)$	Transmission Ratio of external Voltage Divider $R(V_{CC1}/CFG1) / R(CFG1/GNDA)$	$V(V_{CC1}) = (1 + R(V_{CC1}/CFG1) / R(CFG1/GNDA)) * V(R_{REF})$, $R(V_{CC1}/CFG1) + R(CFG1/GNDA) = 10\text{ k}\Omega\text{...}50\text{ k}\Omega \pm 1\%$, $V(V_{CC1}) = 1.5\text{...}5.5\text{ V}$	0.2		3.5	
504	CVCC1	Required Capacitor at VCC1 versus GNDA	tolerance $\pm 30\%$	1	4.7		μF
505	RICVCC1	Permissible Internal Resistance of Capacitor at VCC1				1	Ω
506	$V_{CC1,lir}$	Line Regulation	$I(V_{CC1}) = -100\text{ mA}$, $V_B = 8\text{...}30\text{ V}$	-20		20	mV
507	$V_{CC1,lor}$	Load Regulation	$V_B = 24\text{ V}$, $I(V_{CC1}) = 0\text{...}200\text{ mA}$	-20		20	mV
508	V_{CC1rip}	Output Ripple	$I(V_{CC1}) = -100\text{ mA}$		10		mVpp
Linear Regulator VCC2							
601	$V_{CC2_{nom,hi}}$	Output Voltage	CFG2 = VCC2; $V_B < 5\text{ V}$, $I(V_{CC2}) = -100\text{...}10\text{ mA}$, $V_B \geq 5\text{ V}$, $I(V_{CC2}) = -150\text{...}10\text{ mA}$, $V_B \geq 6.5\text{ V}$, $I(V_{CC2}) = -200\text{...}10\text{ mA}$, $V_B \geq 16\text{ V}$, $I(V_{CC2}) = -300\text{...}10\text{ mA}$, $V_B \geq 24\text{ V}$, $I(V_{CC2}) = -350\text{...}10\text{ mA}$	3.135	3.3	3.465	V
602	$V_{CC2_{nom,lo}}$	Output Voltage	CFG2 = GNDA; $V_B < 5\text{ V}$, $I(V_{CC2}) = -150\text{...}10\text{ mA}$, $V_B \geq 5\text{ V}$, $I(V_{CC2}) = -200\text{...}10\text{ mA}$, $V_B \geq 6.5\text{ V}$, $I(V_{CC2}) = -250\text{...}10\text{ mA}$, $V_B \geq 12\text{ V}$, $I(V_{CC2}) = -300\text{...}10\text{ mA}$, $V_B \geq 24\text{ V}$, $I(V_{CC2}) = -350\text{...}10\text{ mA}$	2.375	2.5	2.625	V
603	$V_r(V_{CC2})$	Transmission Ratio of external Voltage Divider $R(V_{CC2}/CFG2) / R(CFG2/GNDA)$	$V(V_{CC2}) = (1 + R(V_{CC2}/CFG2) / R(CFG2/GNDA)) * V(R_{REF})$, $R(V_{CC2}/CFG2) + R(CFG2/GNDA) = 10\text{ k}\Omega\text{...}50\text{ k}\Omega \pm 1\%$, $V(V_{CC2}) = 1.5\text{...}5.5\text{ V}$	0.2		3.5	
604	CVCC2	Required Capacitor at VCC2 versus GNDA	tolerance $\pm 30\%$	1	4.7		μF
605	RICVCC2	Permissible Internal Resistance of Capacitor at VCC2				1	Ω
606	$V_{CC2,lir}$	Line Regulation	$I(V_{CC2}) = -100\text{ mA}$, $V_B = 8\text{...}30\text{ V}$	-20		20	mV
607	$V_{CC2,lor}$	Load Regulation	$V_B = 24\text{ V}$, $I(V_{CC2}) = 0\text{...}200\text{ mA}$	-20		20	mV
608	V_{CC2rip}	Output Ripple	$I(V_{CC2}) = -100\text{ mA}$		10		mVpp

ELECTRICAL CHARACTERISTICS

Operating conditions: $V_B = +4\text{ V to }+36\text{ V}$, $R_{REF} = 20\text{ k}\Omega \pm 1\%$, $T_J = -40^\circ\text{C to }+125^\circ\text{C}$, reference is GND (GNDA = GND), unless otherwise stated.

Item No.	Symbol	Parameter	Conditions				Unit
				Min.	Typ.	Max.	
Voltage Monitoring V1OK, V2OK (x = 1, 2)							
701	VtU()lo	Lower Undervoltage Threshold VCCx for VxOK = lo	versus VCCxnom	90	92	94	%VCC2
702	VtU()hi	Upper Undervoltage Threshold VCCx for VxOK = hi	versus VCCxnom	91	93	95	%VCC2
703	VtO()lo	Lower Overvoltage Threshold VCCx for VxOK = hi	versus VCCxnom	105	107	109	%VCC2
704	VtO()hi	Upper Overvoltage Threshold VCCx for VxOK = lo	versus VCCxnom	106	108	110	%VCC2
705	Vt()hys	Hysteresis Under-/Overvoltage VCCx	versus VCCxnom	0.25	1	1.5	%VCC2
706	Vs()lo	Saturation Voltage lo	VxOK = lo; I() = 4 mA, VCCx \geq 3 V I() = 1 mA, VCCx < 3 V			0.4 0.4	V V
707	Vs()hi	Saturation Voltage hi	Vs()hi = VCCx – V(), VxOK = hi; I() = -4 mA, VCC2 \geq 3 V I() = -1 mA, VCC2 < 3 V			0.4 0.4	V V
708	Isc()lo	Short-Circuit Current lo	V() = VCCx, VxOK = lo; VCCx \geq 3 V VCCx < 3 V	6 1		90 30	mA mA
709	Isc()hi	Short-Circuit Current hi	V() = 0 V, VxOK = hi; VCCx \geq 3 V VCCx < 3 V	-100 -30		-6 -1	mA mA
Supply Switches POE1, POE2 (x = 1, 2)							
801	Vs()hi	Saturation Voltage hi	Vs()hi = VCCx – V(POEx); V(VCCx) \geq 2.5 V, I(POEx) = -10 mA, V1OK, V2OK = hi			0.2	V
802	Vs()hi	Saturation Voltage hi	Vs()hi = VCCx – V(POEx); V(VCCx) < 2.5 V; I(POEx) = -5 mA, V1OK, V2OK = hi			0.2	V
803	Isc()hi	Short-Circuit Current hi	V(POEx) = 0 V; V(VCCx) \geq 2.5 V, POEx = hi, V1OK, V2OK = hi	-40		-12	mA
804	Isc()hi	Short-Circuit Current hi	V(POEx) = 0 V; V(VCCx) < 2.5 V, POEx = hi, V1OK, V2OK = hi	-30		-6	mA
Thermal Shutdown and Error Detection TOK							
901	Toff	Thermal Shutdown Threshold		150	160	175	$^\circ\text{C}$
902	Ton	Restart Temperature		135	150	165	$^\circ\text{C}$
903	Thys	Temperature Hysteresis	Thys = Toff – Ton	5	10	20	$^\circ\text{C}$
904	Vs()lo	Saturation Voltage lo	I(TOK) = 5 mA; TOK = lo			0.4	V
905	Isc()lo	Short-Circuit Current lo	V(TOK) = 2..8 V; TOK = lo		10	20	mA
906	Ik()	Leakage Current	V(TOK) = 0..8 V; TOK = hi	-10		10	μA
Test Input TEST							
A01	Vt()hi	Threshold Voltage hi for Comparator test			0.65	0.75	V
A02	Vt()lo	Threshold Voltage lo for Comparator test		0.5	0.6		V
A03	Vt()hys	Hysteresis at TEST	Vt() = Vt(TEST)hi – Vt(TEST)lo	10	50	100	mV
A05	Ipd()	Pull-Down Current in TEST	V() = 5.5 V	20		200	μA
A07	tsu(TEST)	Settling Time at V1OK, V2OK	V1OK, V2OK changing hi \rightarrow lo	10	20	30	μs
A08	tsu(TEST)	Settling Time at V1OK, V2OK	V1OK, V2OK changing of lo \rightarrow hi	2	4	8	μs

DESCRIPTION OF FUNCTIONS

DC/DC converter iC-DC generates two regulated voltages of VH1 and VH2 from voltage VBR. These pre-stabilize the two linear regulators VCC1 and VCC2. A third voltage of VH, also regulated, is generated to drive these linear regulators. Voltage supply VB may be either above or below the output voltages. Figure 1 shows the basic function principle of iC-DC. Switches S1 to S6 and diode D1 have been implemented on the chip. The inductor, capacitors, and load resistors are external devices.

Another feature of iC-DC is that bias voltages VH1 and VH2 adjust themselves automatically to approximately 400 mV using the selected VCC1 or VCC2 voltage. This results in minimum power dissipation as only a low amount of voltage is lost through each of the linear regulators.

Charge/discharge phase

During the charge phase switches S1 and S2 close with the internal clock. A linearly increasing current flows through coil LVBH. The energy from supply VBR is stored in the coil's magnetic field.

Switches S1 and S2 open for discharging. Switch S3 and one of the switches S4/S5/S6 are closed. The current can continue to flow in the coil and is supplied to the relevant capacitor and relevant load. Figure 2 describes the resulting course of the current and voltage. The current rise and fall times depend on the inductor voltage.

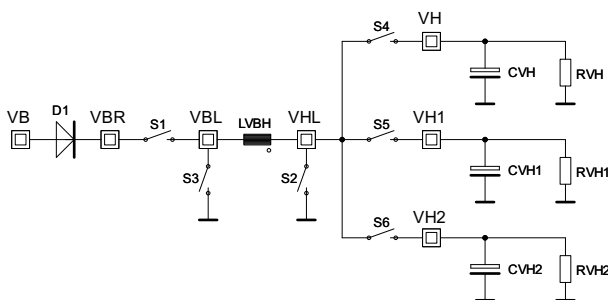

Figure 1: Principle of operation of the converter

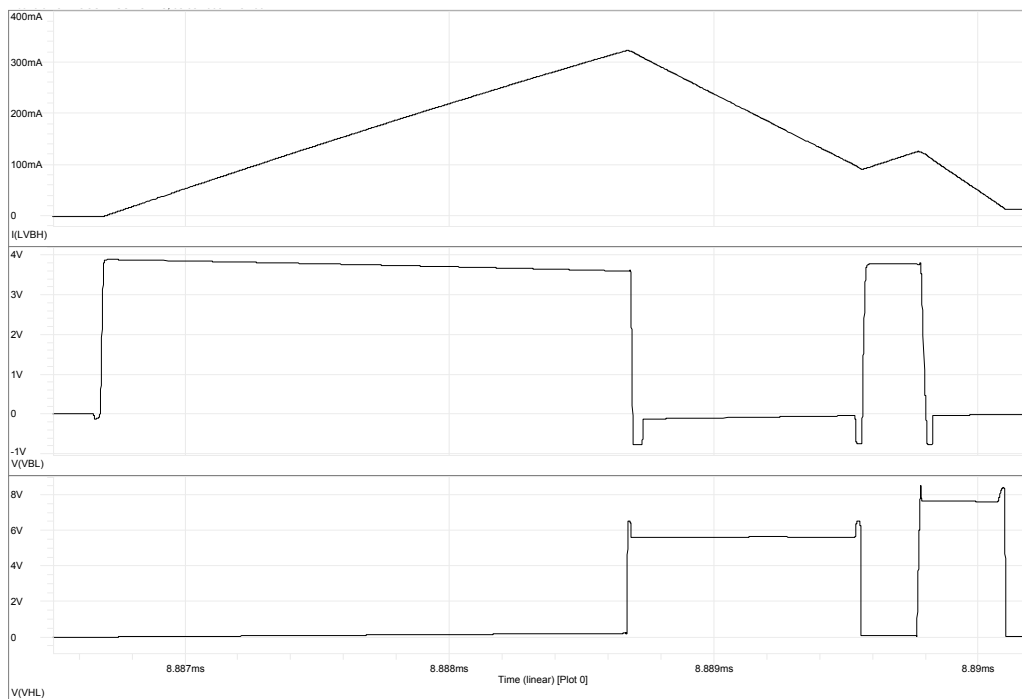

Figure 2: Converter current/voltage characteristics (VB = 4 V)

Intermittent flow / continuous flow

If the inductor is recharged in the next cycle before the coil current has run free, there is no gap in the current. This *continuous flow* occurs when the supply voltage is low or the load current high.

If the charge and discharge processes are concluded within one clock cycle and the coil current drops to zero each time, *intermittent flow* prevails. This is the case when the supply voltage is sufficiently high or the load current sufficiently low.

When no more current flows through the coil, after fly-back in *intermittent operation* both ends of the inductor are switched to ground. This prevents the oscillations in no-load operation that are typical of many converters (RLC resonating circuit). This helps to achieve better EMC behavior.

Startup behavior

During startup and with low supply voltages the coil's maximum cut-off current is reduced (soft start) until the nominal voltage is reached at VH. Figure 3 shows the startup behavior for VH, VCC1 (5 V), and VCC2 (3.3 V) with the voltage monitor outputs V1OK and V2OK.

As three output voltages are generated with this switching converter topology using just one single inductor, the sequence must allow that all three converter outputs are respectively supplied with the required current. The core of the converter consists of three independent converters. Each converter has its own regulated cut-off and restart current and its own voltage monitor. During the startup phase the VH converter ramps up until a voltage of approximately 7 V is obtained. Here, the cut-off current is initially limited to lower values so that a *soft start* with a low startup current ripple is achieved. When a high enough VH voltage is available, the VH1 and VH2 converters are also switched on and the voltages rise to their nominal values. Once in a steady state, the individual converters are cyclically supplied by the inductor with precisely the amount of current that is required at that moment. The maximum load current can thus be drawn from each of the voltages VH, VH1, VH2, VCC1, or VCC2.

Standby

The converters can be individually activated by pins ENV1 and ENV2. If neither of the two inputs are triggered, the device is in standby mode and the current consumption is reduced to a minimum. As soon as one of the two inputs becomes active, the VH voltage is also available.

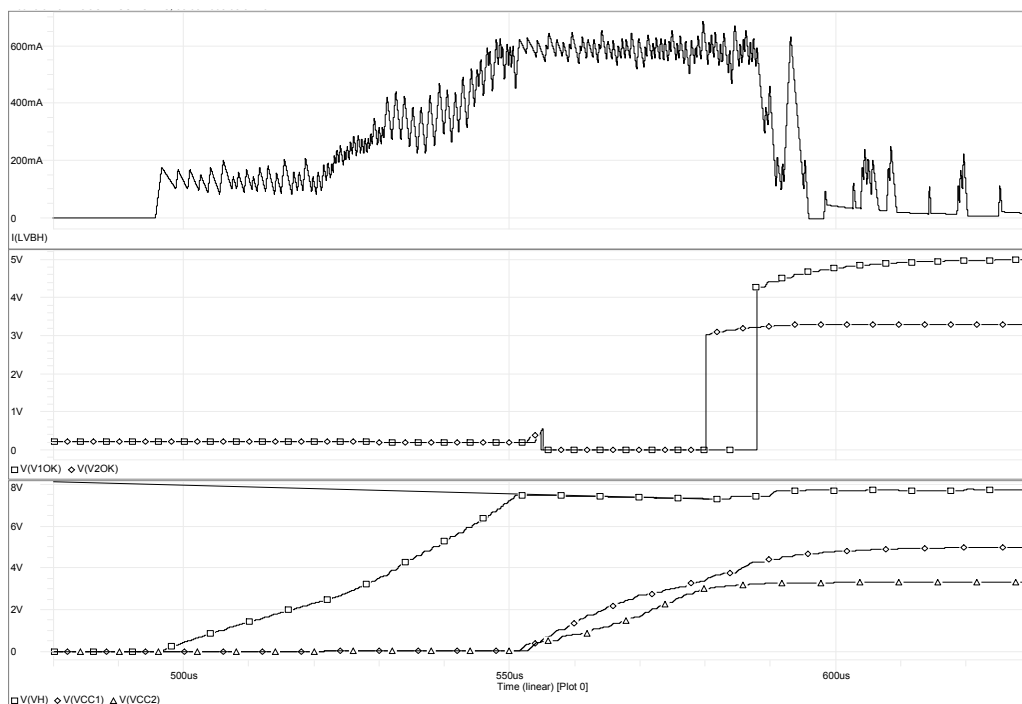

Figure 3: Startup principle for voltages VH, VCC1, VCC2, V1OK, and V2OK

LINEAR REGULATORS VCC1 AND VCC2

To achieve as low an interference voltage as possible, even with small filter capacitors C_{VH1} and C_{VH2} , an independent linear regulator is connected after each of the intermediate voltages $VH1$ and $VH2$.

Output voltages $VCC1$ and $VCC2$ can each be adjusted using a voltage divider at $CFG1$ and $CFG2$ within a range of 1.5 to 5.5 V $\pm 5\%$ and according to Equations 1 and 2.

$$V_{VCC1} = V(RREF) \times \left(1 + \frac{R_1}{R_2}\right) \quad (1)$$

and

$$V_{VCC2} = V(RREF) \times \left(1 + \frac{R_3}{R_4}\right) \quad (2)$$

NB: $R_1 + R_2$ and $R_3 + R_4 = 10\text{ k}\Omega$ up to $50\text{ k}\Omega$
 $V(RREF)$ Electrical Characteristics 401

Inputs $CFG1$ and $CFG2$ can also be directly connected to the relevant output voltage $VCCx$ or $GNDA$. The resulting voltages are given in Tables 1 and 2.

VCC1 output voltage	
Potential at CFG1	VCC1
GNDA	3.3 V
VCC1	5.0 V
Voltage divider	1.5 V to 5.5 V

Table 1: VCC1 settings

VCC2 output voltage	
Potential at CFG2	VCC2
GNDA	2.5 V
VCC2	3.3 V
Voltage divider	1.5 V to 5.5 V

Table 2: VCC2 settings

The regulators have been compensated internally so that they are stable in no-load operation without an external capacitor. Stability across the entire load range is guaranteed by the minimum capacitances for C_{VCC1} and C_{VCC2} given in the electrical characteristics. The outputs are current limited to protect them against destruction in the event of a short circuit.

The two linear regulators can be switched on and off independently by inputs $ENV1$ and $ENV2$. If both regu-

lators are deactivated, iC-DC is in standby mode (see DESCRIPTION OF FUNCTIONS/Standby).

Switched output voltages

The two pins $POE1$ and $POE2$ are triggered by monitor outputs $V1OK$ and $V2OK$ and provide voltages drawn from $VCC1$ or $VCC2$. This enables the supply of specific circuitry in a component group (e.g. EEPROMs) to be switched on only after $VCC1$ or $VCC2$ have reached their steady state.

Voltage monitor self-test

Using pin $TEST$ the voltage monitoring comparators at $V1OK$ and $V2OK$ can be tested during ongoing operation. The undervoltage and overvoltage thresholds of $V1OK$ and $V2OK$ are checked in turn with each test. For this purpose, pin $TEST$ is increased to above the threshold voltage by an external driver. Correct functioning is signaled by low signals at pins $V1OK$ and $V2OK$. The function of the connected $POE1$ and $POE2$ outputs remains unaffected.

Current carrying capacity

iC-DC's current carrying capacity depends on set output voltage $VCCx$ and input voltage VB . Figure 4 shows the current carrying capacity dependent on the input voltage for various output voltages, measured on the iC-DC EVAL DC1D evaluation board. The internal reverse polarity protective circuit was bridged ($VB = VBR$) to increase the current carrying capacity.

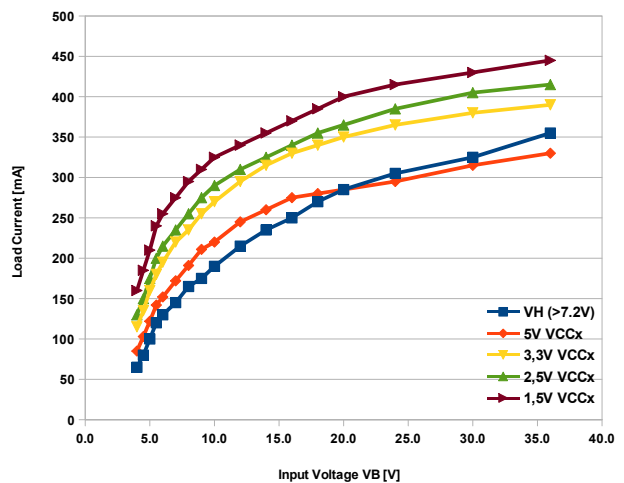

Figure 4: Current carrying capacity for various output voltages dependent on VB ($VB = VBR$)

REVERSE POLARITY PROTECTION

A protective switch inserted between supply VB and pin VBR protects the entire system against reverse polarity. This can also be used to implement an Autarky function (see AUTARKY FUNCTION). By connecting VB to VBR the reverse polarity protection circuit can be bridged to improve the current carrying capacity and the overall efficiency, especially if low supply voltages are used (Figure 5).

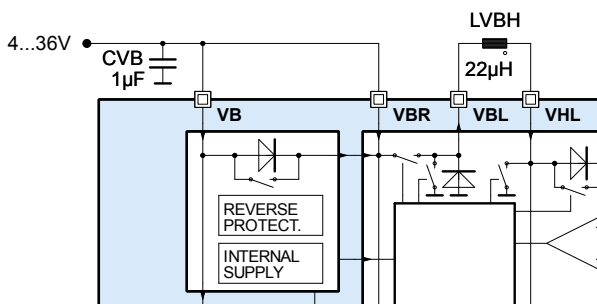

Figure 5: Protection against reverse polarity deactivated, bridges VB to VBR

The reverse polarity protection switch is current limited to the maximum mean current consumption of the system (Electrical Characteristics 104). A capacitor (CVBR) must be connected to pin VBR if higher coil cut-off currents are to be supplied.

This capacitor should have a value of at least 1 µF at a supply voltage of VB = 24 V (Figure 6). With very small supply voltages the value must be greater in order to cater for the higher power consumption during startup. The voltage at VBR must no longer drop below the lower shutdown threshold (Electrical Characteristics 202) to ensure safe converter startup. A capacitor of approx. 10 µF should thus be selected for CVBR at a supply voltage of VB = 4 V (Figure 7).

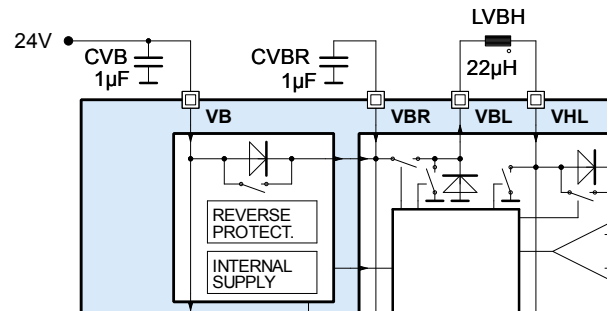

Figure 6: Protection against reverse polarity active, CVBR for VB = 24 V

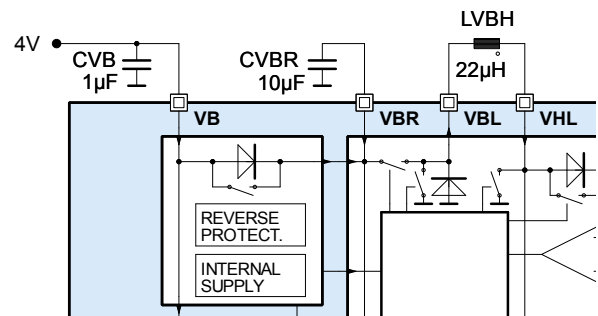

Figure 7: Protection against reverse polarity active, CVBR for VB = 4 V

It is possible to use the protective switch at pin VBR to provide further circuitry with protection against reverse polarity (Figure 9, Page 17). Here, it must be noted that the current carrying capacity of the reverse polarity protection (VBR) is limited on startup. As the device powers itself from VBR, the load at VBR must not be too high as otherwise converter operation cannot be initiated. The current carrying capacity on startup can be approximately described by Equation 3:

$$I(VBR) = V(VB) * \frac{-1mA}{V} \quad (3)$$

ERROR EVALUATION**Supply voltage monitor**

Supply voltage VBR is monitored. If the normal voltage range is overshoot or undershot, this is signaled at open-drain pin VBROK. The bias current generated by an external reference resistor is also monitored and an error signaled at VBROK should the permissible range be exceeded. If an error has occurred, pin VBROK is switched to GND.

Output voltage monitor

The two linear regulator output voltages VCC1 and VCC2 are also monitored. If the overvoltage threshold is overshoot or the undervoltage threshold undershot (e.g. due to overload), a message is generated at the current-limited push-pull outputs V1OK and V2OK. Voltage outputs POE1 and POE2 are shut down.

Output voltage monitor self-test

Using pin TEST the voltage monitoring comparators at V1OK and V2OK can be tested during ongoing operation. The undervoltage and overvoltage thresholds of V1OK and V2OK are checked in turn with each test. For this purpose, pin TEST is increased to above the threshold voltage by an external driver. Correct functioning is signaled by low signals at pins V1OK and

V2OK. The function of the connected POE1 and POE2 outputs remains unaffected.

Temperature monitor

The internal chip temperature is monitored. If the monitor indicates overtemperature, all switches on the switching converter are shut down. These are automatically re-enabled when the chip temperature has dropped below the restart temperature. A message is signaled at open-drain pin TOK for as long as the converter is shut down due to chip overtemperature.

The protective switch (VB / VBR) has its own over temperature protection, which is also operative during standby mode.

As error outputs VBROK and TOK are current limited, an LED can be directly connected up for visual message display. However, the additional power dissipation this causes in the IC must be taken into account. By placing resistor R_{LED} in series with the LED, this additional chip power loss can be reduced in the event of error. CMOS or TTL-compatible logic inputs can be activated by pull-up resistors at VBROK and TOK.

AUTARKY FUNCTION

By inserting a capacitor at VBR, an Autarky function can be realized should the supply fail at VB. This Autarky function guarantees the linear regulator output voltages for some time. If the voltage at VBR is greater than at VB (elec. char. no. 109), this is signaled by current-limited open-drain output NAUT. To ensure that $VBR > VB$ should the supply voltage fail, it is recommended that a

resistor be switched between VB and GND in order to generate the required differential voltage of $d_{VBR,VB}$.

With this capacitor acting as a buffer, the effect of current spikes feeding back into the supply voltage VB is also reduced.

DESCRIPTION OF THE APPLICATION

Selecting the coil

The coil should be designed for a DC current and saturation current of min. 0.8 A. A small internal resistor in the coil reduces loss and increases converter efficiency. At a low supply voltage this internal resistor can determine the maximum available output current.

The EMI caused by the coil should be taken into consideration. Toroidal core coils have little noise radiation yet are expensive and difficult to install. Bar core coils are reasonably priced and easier to use yet have a higher noise emittance. For modest EMI requirements inexpensive radio interference suppression coils of several tens of μH are suitable*.

Selecting the capacitors

For selecting back-up capacitors C_{VH} , C_{VH1} and C_{VH2} please ref to elec. char. item 307, 311, 315. As the residual ripple of intermediate voltages VH1 and VH2 does not affect output voltages VCC1 and VCC2 thanks to the back-end linear regulators, a small capacitor is sufficient without any specific demands being made of the internal resistor. A combination of electrolytic and ceramic capacitors (e.g. $3.3 \mu\text{F} \parallel 100 \text{nF}$) is recommended. Before using tantalum capacitors, the user must verify whether these are suitable for the residual AC amplitude (residual ripple) at pins VH1 and VH2 .

Stability of the linear regulators across the entire load area is guaranteed if the values given in the electrical characteristics are selected for CVCC1 and CVCC2 . The suppression of interference voltage is improved by using small capacitor series resistors. A combination of tantalum and ceramic capacitors is also recommended in this case. If one of the two outputs remains open, this capacitor can be omitted.

To avoid feedback of interference from supply voltage VB onto output voltages VCC1 and VCC2 , blocking should be provided directly at pin VB . A combination of tantalum and ceramic capacitors (e.g. $1 \mu\text{F} \parallel 100 \text{nF}$) is also recommended in this case.

Printed circuit board layout

The GND path from the switching converter and from each linear regulator should be strictly separated to avoid cross couplings. The neutral point of all GND paths is the GND connection at iC-DC. It is possible and not critical, however, to route GND from supply VB and the base point of capacitors C_{VH} , C_{VH1} and C_{VH2} together to the neutral point. The capacitors should be very close to their relevant pins, however.

Blocking capacitors for supply VB should be arranged as close as possible to pins VB and GND. The capacitors for outputs VCC1 and VCC2 should be placed directly at the load and not at the IC to also block interferences which are coupled via the wiring to the load.

The ground planes underneath the wiring of output voltages VCC1 , VCC2 , POE1 , and POE2 should be kept separate from the ground planes of switching converters VH , VH1 , and VH2 . The ground planes must be connected up at a neutral point (see Figure 8).

The thermal pad should be connected to the PCB by an appropriate ground plane. The resulting power dissipation can be transferred to a different wiring layer, e.g. a ground plane, by vias directly underneath the IC.

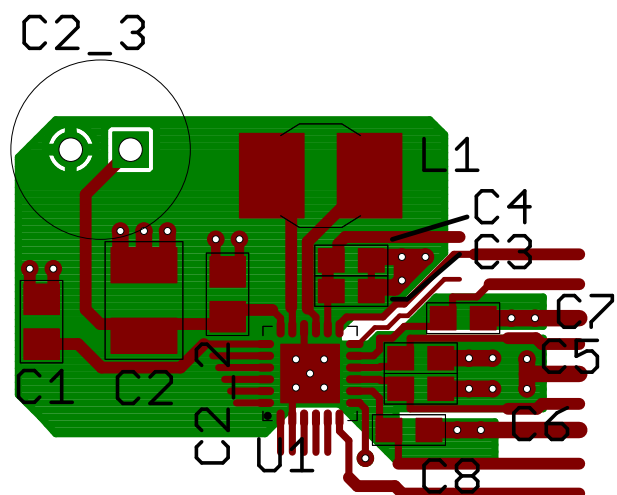

Figure 8: Example layout: evaluation board DC1D

* e.g.: Würth no.: 74437324220 (22 μH , 1A, SMD shielded), Siemens Matsushita B78108-S1223-J (22 μH /1A, axial), TDK series NLC565050T-... (SMD), TOKO series 10RF459-... (SMD shielded)

EXAMPLE APPLICATION

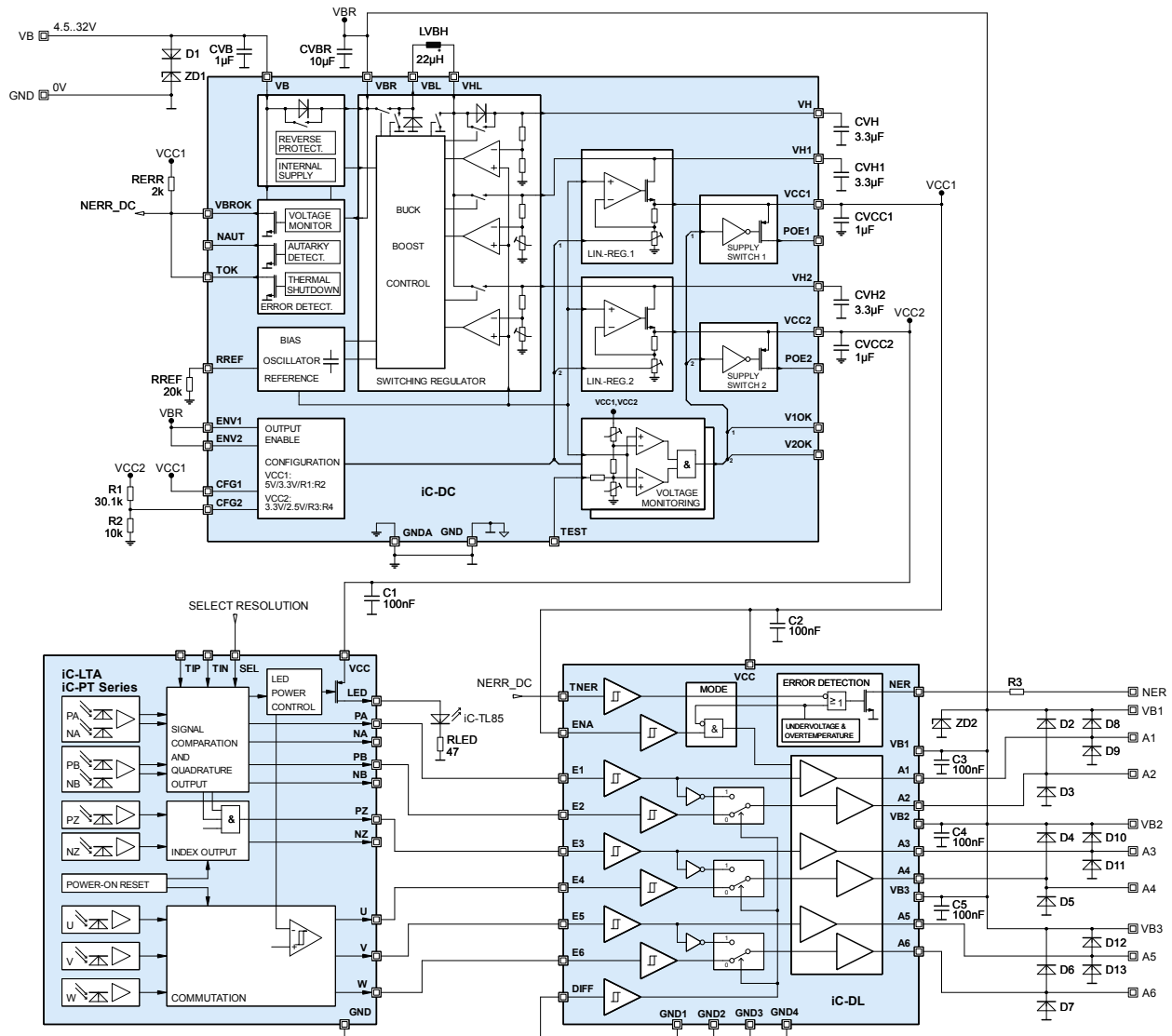

Figure 9: Application with iC-DC, iC-PT, and iC-DL

The application diagram in Figure 9 shows an example circuit featuring the DC/DC converter iC-DC. The input voltage range is set to between 4.5 V and 32 V by line driver iC-DL. The output voltages of the two linear regulators are each configured to 5 V. VCC2 supplies the optical 6-channel incremental scanner iC-LTA/iC-PT and VCC1 the 5 V section of 24 V line driver iC-DL. This creates a separation in the supply voltage between the sensing mechanism and the digital switching section of the circuitry.

The status signals for overvoltage (VBROK) and overtemperature (TOK) in iC-DC are connected to iC-DL's error message input TNER. This links the

iC-DC error messages to iC-DL's own undervoltage and overtemperature monitor. iC-DL's open-drain error message output NER thus provides the error messages for both ICs.

This example circuit makes use of iC-DC's integrated reverse polarity protection feature. The illustrated diodes ZD1, ZD2, D2 to D13 and resistor R3 form the basis for a protective circuit against overvoltage for all outputs. No specific designations are given for these components as these protective circuits are to be individually configured and dimensioned according to the application and requirement.

DESIGN REVIEW: Notes On Chip Functions

iC-DC Z		
Nr.	Function, Parameter/Code	Description and Application Hints
1		None at time of release.

Table 3: Notes on chip functions regarding iC-DC chip release Z

iC-DC Z1		
Nr.	Function, Parameter/Code	Description and Application Hints
1		None at time of release.

Table 4: Notes on chip functions regarding iC-DC chip release Z1

REVISION HISTORY

Rel.	Rel. Date [†]	Chapter	Modification	Page
B1	2017-08-31	ABSOLUTE MAXIMUM RATINGS	Item G001: changed min. -40V to -38.5V	6
		THERMAL DATA	Item T01: changed max. 125°C to 105°C	6
		ELECTRICAL CHARACTERISTICS	Item 002: changed max. 200 µA to 400µA Item 003: for VB = 4 V changed max. 50 mA to 60mA Item 004: for VB = 4 V changed max. 60 mA to 70mA Item 013: condition changed from -2 mA to -5 mA, max. value changed -42 V to -38.5 V Item 101: changed max 0.6 V to 0.7 V Item 104: typ. value removed, changed max. -120 mA to -80mA, min. -500 mA to -600mA Item 105: changed max. -150 mA to -250 mA Item 213: changed min. 3.2 V to 3.3 V Item 307: added typ. 4.7µF Items 311 and 311: changed min. 1 µF to 2.2, added typ. 10 µF Item 401: changed min. 1.18 V to 1.16 V and max. 1.30 V to 1.32 Item 404: changed min. 2 MHz to 1.8 MHz Item 504 and 604: added typ. 4.7 µF Item 708: for VCCx ≥ 3 V changed max. 80 mA to 90 mA Item A01: changed typ. 0.64 V to 0.65 V and max. 0.7 V to 0.75 V Item A02: changed min. 0.54 V to 0.5 V Item A03: changed typ. 40 mA to 50 mA	7 - 10
		LINEAR REGULATORS VCC1 AND VCC2	Figure 4 corrected Y-axis description from µA into mA	13
		DESCRIPTION OF THE APPLICATION	Coil requirement changed from cut off current 1A to DC current and saturation current of min. 0.8A Corrected coil type: Siemens Matsushita B78108-S1223-J (22 µH/1 A, axial) Added Würth no.: 74437324220 (22µH, 1A, SMD shielded)	16
		DESIGN REVIEW: Notes On Chip Functions	Removed for revision iC-DC Z due to changing of elec. char. no.: 013	18
			Preliminary removed	all

Rel.	Rel. Date [†]	Chapter	Modification	Page
B2	2023-01-23	ELECTRICAL CHARACTERISTICS	Item 013: condition changed from -5mA to -10mA	7
		DESIGN REVIEW: Notes On Chip Functions	Added new chip revision iC-DC Z1 (with no remarks)	18

[†] Release Date format: YYYY-MM-DD

iC-DC

2-CHANNEL BUCK/BOOST DC/DC CONVERTER



Rev B2, Page 19/20

iC-Haus expressly reserves the right to change its products, specifications and related supplements (together the Documents). A Datasheet Update Notification (DUN) gives details as to any amendments and additions made to the relevant Documents on our internet website www.ichaus.com/DUN and is automatically generated and shall be sent to registered users by email.

Copying – even as an excerpt – is only permitted with iC-Haus' approval in writing and precise reference to source.

The data and predicted functionality is intended solely for the purpose of product description and shall represent the usual quality and behaviour of the product. In case the Documents contain obvious mistakes e.g. in writing or calculation, iC-Haus reserves the right to correct the Documents and no liability arises insofar that the Documents were from a third party view obviously not reliable. There shall be no claims based on defects as to quality and behaviour in cases of insignificant deviations from the Documents or in case of only minor impairment of usability.

No representations or warranties, either expressed or implied, of merchantability, fitness for a particular purpose or of any other nature are made hereunder with respect to information/specification resp. Documents or the products to which information refers and no guarantee with respect to compliance to the intended use is given. In particular, this also applies to the stated possible applications or areas of applications of the product.

iC-Haus products are not designed for and must not be used in connection with any applications where the failure of such products would reasonably be expected to result in significant personal injury or death (*Safety-Critical Applications*) without iC-Haus' specific written consent. Safety-Critical Applications include, without limitation, life support devices and systems. iC-Haus products are not designed nor intended for use in military or aerospace applications or environments or in automotive applications unless specifically designated for such use by iC-Haus.

iC-Haus conveys no patent, copyright, mask work right or other trade mark right to this product. iC-Haus assumes no liability for any patent and/or other trade mark rights of a third party resulting from processing or handling of the product and/or any other use of the product.

Software and its documentation is provided by iC-Haus GmbH or contributors "AS IS" and is subject to the ZVEI General Conditions for the Supply of Products and Services with iC-Haus amendments and the ZVEI Software clause with iC-Haus amendments (www.ichaus.com/EULA).

ORDERING INFORMATION

Type	Package	Order Designation
iC-DC	QFN24 4 mm x 4 mm	iC-DC QFN24-4x4
	Evaluation Board	iC-DC EVAL DC1D

Please send your purchase orders to our order handling team:

Fax: +49 (0) 61 35 - 92 92 - 692

E-Mail: dispo@ichaus.com

For technical support, information about prices and terms of delivery please contact:

iC-Haus GmbH
Am Kuemmerling 18
D-55294 Bodenheim
GERMANY

Tel.: +49 (0) 61 35 - 92 92 - 0
Fax: +49 (0) 61 35 - 92 92 - 192
Web: <https://www.ichaus.com>
E-Mail: sales@ichaus.com

Appointed local distributors: https://www.ichaus.com/sales_partners