

iC-WKP

15 V CW P-TYPE LASER DIODE DRIVER



Rev B1, Page 1/12

FEATURES

- ◆ Optimised for P-type laser diodes (case grounded)
- ◆ CW operation up to 350 mA from 3 to 15 V supply voltage
- ◆ Rapid soft start after power-on
- ◆ Simple power adjustment via an external resistor
- ◆ Control loop accuracy better than 2% with changes in temperature, supply voltage and load current
- ◆ Integrated reverse polarity protection for the iC and laser diode
- ◆ Strong suppression of transients with small external capacitors; integrated flyback path
- ◆ Permanent shutdown with excessive chip temperature and overcurrent (i.e. if the laser diode is damaged or the feedback current path fails)
- ◆ Second feedback input MDA also permits the operation of N-type laser diodes
- ◆ Modulation via the feedback inputs possible
- ◆ Wide monitor current range from 2.5 μ A to 6.25 mA

APPLICATIONS

- ◆ Laser diode modules
- ◆ Laser diode pointers
- ◆ Pilot lasers
- ◆ Laser levels
- ◆ Barcode readers
- ◆ Distance measuring sensors

PACKAGES

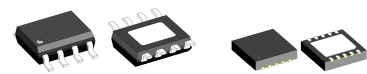

SO8-TP
(thermal pad)

DFN10
4 mm x 4 mm x 0.9 mm
RoHS compliant

BLOCK DIAGRAM

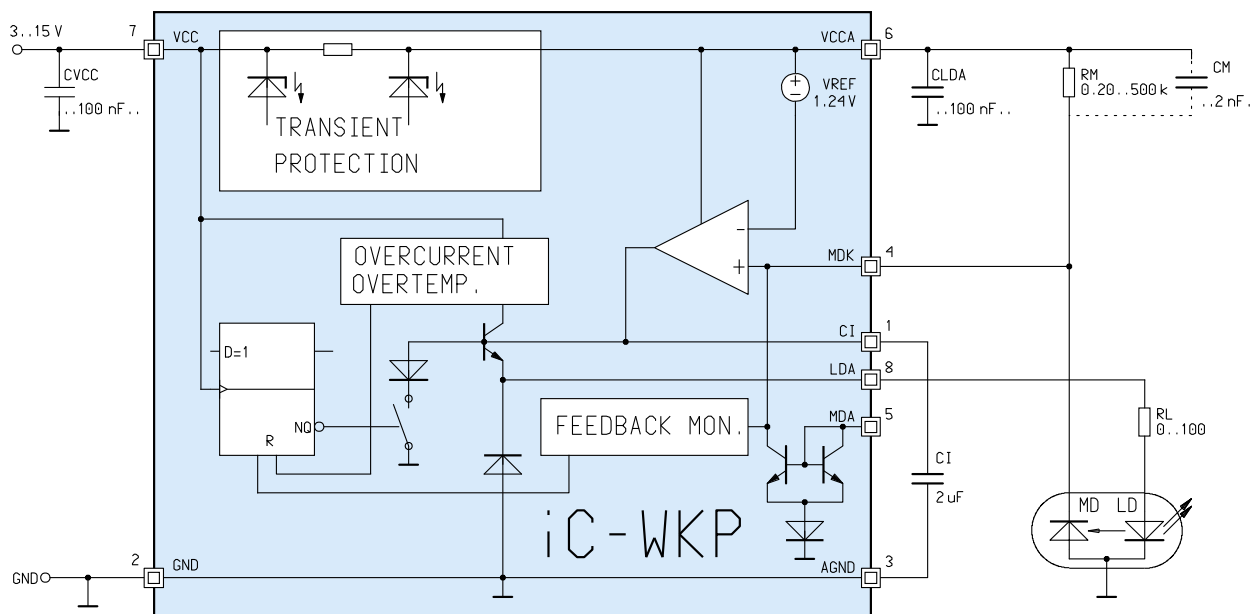

suitable laser diode configurations:

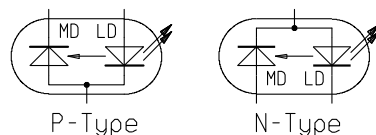

Pin numbers given for SO8 package only.

DESCRIPTION

iC-WKP is a driver for laser diodes in continuous wave (CW) operation with laser currents of up to 350 mA from a wide power supply range of up to 15 V which requires only four external components. The driver is optimised for P-type laser diodes and allows the connection of the laser diode case to ground.

The iC includes integrated circuitry protecting against destruction by ESD, excessive temperature and overcurrent plus a soft start of the regulator to protect the laser diode when the power supply is switched on. The iC also filters the laser diode power supply for transients.

The regulator is adapted to the laser diode by an external resistor at MDK. The monitor current acts as a reference and is regulated independent of the influence of temperature and supply voltage (range:

2.5 μ A to 6.25 mA). The capacitor at CI determines the control time constants and start-up time.

A second monitor input, pin MDA, allows the driver to be used for N-type laser diode configuration; alternatively, it can be used as an analogue modulation input (DC to a few kHz).

In the event of failure, such as overcurrent in the laser path with a lack of feedback, for example, a quick power lockout is activated. The shutdown persists until power is reapplied, permitting a restart. The strain on power packs and batteries is relieved and the laser class is retained even in the event of a disturbance.

iC-WKP offers additional protection by means of spike detection at pin MDK. Should spikes or oscillation occur at pin MDK the power lockout is activated after a certain time-out.

PACKAGING INFORMATION SO8-TP, DFN10 4 mm x 4 mm to JEDEC standard

PIN CONFIGURATION SO8-TP

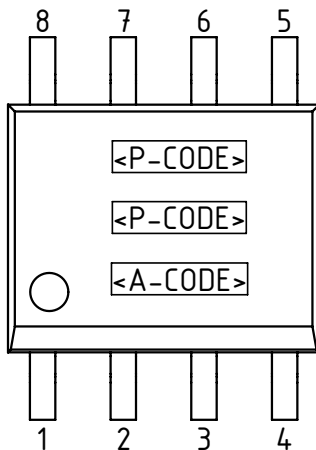

PIN FUNCTIONS

No. Name Function

1	CI	Capacitor for Power Control
2	GND	Ground
3	AGND	Reference Ground for CI
4	MDK	APC Setup, Monitor Input 1 (MD Cathode)
5	MDA	Monitor Input 2 (MD Anode, modulation)
6	VCCA	Driver Supply
7	VCC	+3 to +15V Supply Voltage
8	LDA	Driver Output (LD Anode)

The *Thermal Pad* is to be connected to a Ground Plane on the PCB. Do not short-circuit pins AGND and GND, for this may deteriorate the precision of the regulator and interfere with the soft-start!

PIN CONFIGURATION DFN10 4 mm x 4 mm

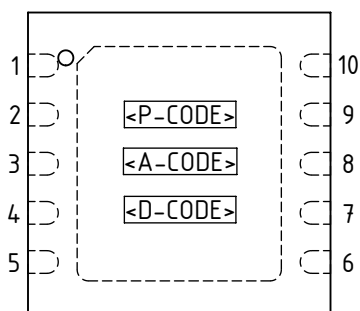

PIN FUNCTIONS

No. Name Function

1	CI	Capacitor for Power Control
2	GND	Ground
3	AGND	Reference Ground for CI
4	MDK	APC Setup, Monitor Input 1 (MD Cathode)
5	n.c.	
6	MDA	Monitor Input 2 (MD Anode, modulation)
7	VCCA	Driver Supply
8	VCC	+3 to +15V Supply Voltage
9	LDA	Driver Output (LD Anode)
10	n.c.	

Orientation of the package label (© iC-WKP ... yyww) may vary!

The *Thermal Pad* is to be connected to a Ground Plane on the PCB. Do not short-circuit pins AGND and GND, for this may deteriorate the precision of the regulator and interfere with the soft-start!

PACKAGE DIMENSIONS SO8-TP

SIDE

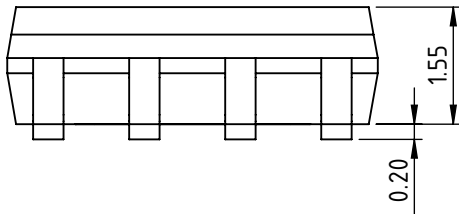

FRONT

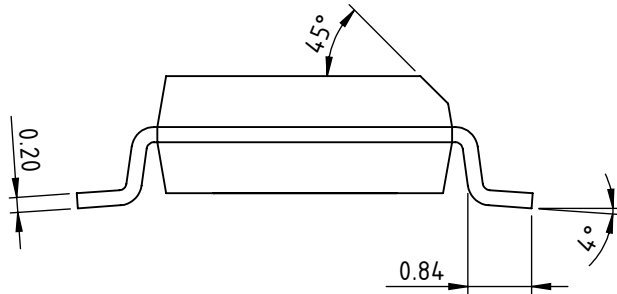

TOP

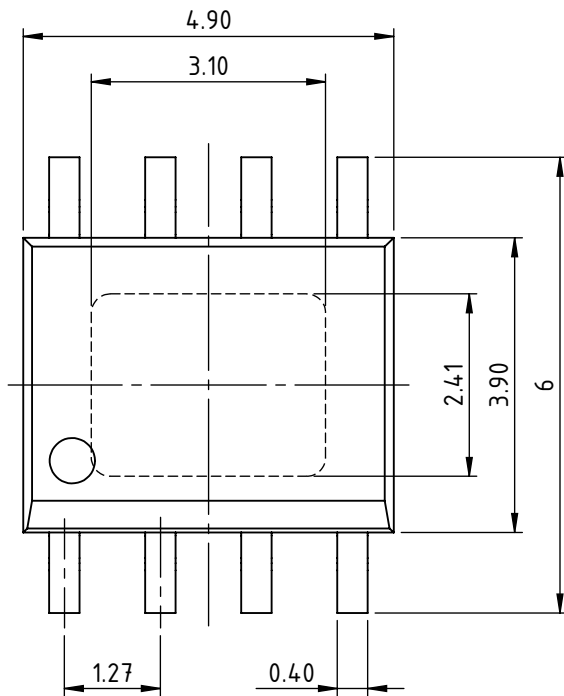

RECOMMENDED PCB-FOOTPRINT

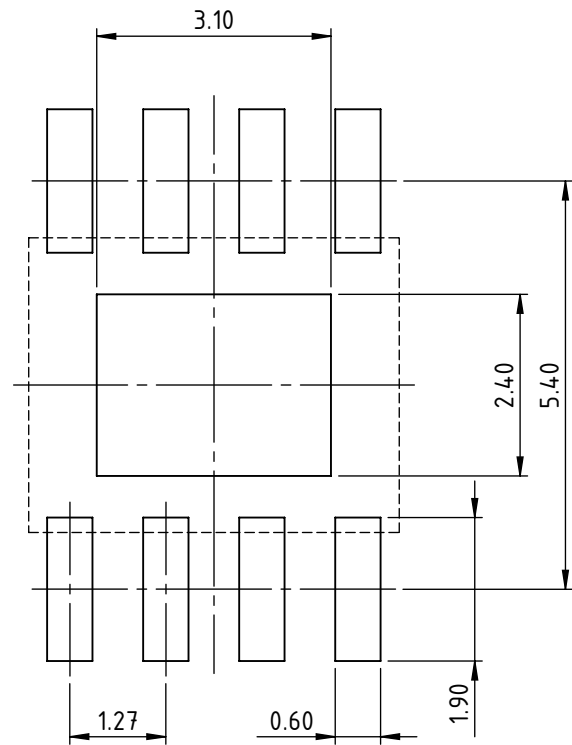

PACKAGE DIMENSIONS DFN10 4 mm x 4 mm

RECOMMENDED PCB-FOOTPRINT

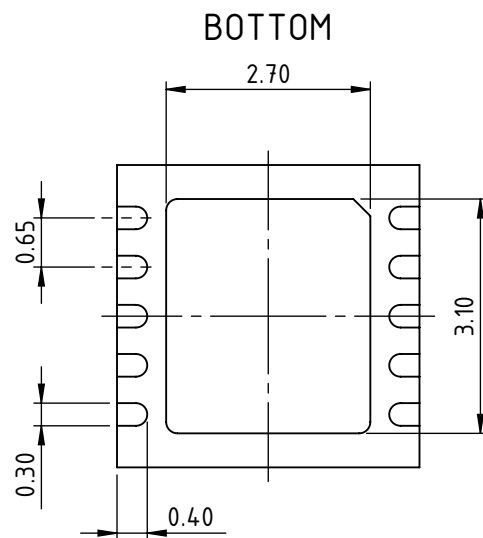
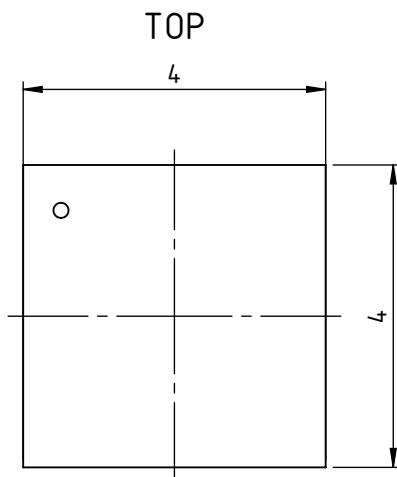
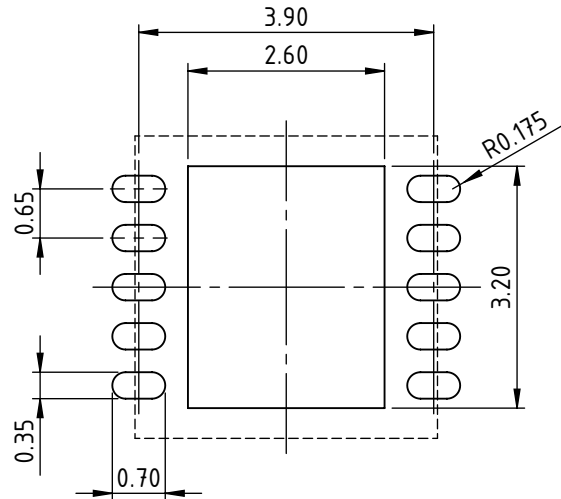
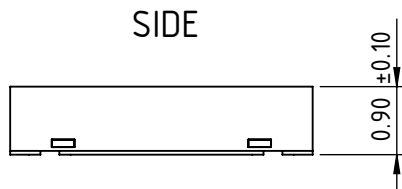

All dimensions given in mm.
Tolerances of form and position according to JEDEC MO-229.

ABSOLUTE MAXIMUM RATINGS

Beyond these values damage may occur; device operation is not guaranteed.

Item No.	Symbol	Parameter	Conditions	Min. Max.		Unit
				Min.	Max.	
G001	VCC	Voltage at VCC		-6	16	V
G002	I(VCC)	Current in VCC		-10	900	mA
G003	I(CI)	Current in CI		-10	10	mA
G004	I(LDA)	Current in LDA		-900	10	mA
G005	I(VCCA)	Current in VCCA		-10	10	mA
G006	I(MDA)	Current in MDA		-10	10	mA
G007	I(MDK)	Current in MDK		-10	10	mA
G008	I(AGND)	Current in AGND		-10	10	mA
G009	I(GND)	Current in GND		-10	900	mA
G010	Vd()	ESD susceptibility at all pins	HBM, 100 pF discharged through 1.5 k Ω		2	kV
G011	Tj	Operating Junction Temperature		-40	150	$^{\circ}$ C
G012	Ts	Storage Temperature Range		-40	150	$^{\circ}$ C

THERMAL DATA

Operating Conditions: VCC = 3...15 V

Item No.	Symbol	Parameter	Conditions	Min. Typ. Max.			Unit
				Min.	Typ.	Max.	
T01	Ta	Operating Ambient Temperature Range		-40		85	$^{\circ}$ C
T02	Rthja	Thermal Resistance Chip/Ambient	SMD assembly, no additional cooling areas			170	K/W
T03	Rthja	Thermal Resistance Chip/Ambient	Therm. pad soldered to approx. 2 cm 2 cooling area		30	50	K/W

All voltages are referenced to ground unless otherwise stated.

All currents flowing into the device pins are positive; all currents flowing out of the device pins are negative.

ELECTRICAL CHARACTERISTICS

Operating Conditions: VCC = 3...15 V, RM = 0.2...500 kΩ, Tj = -40...125 °C unless otherwise stated

Item No.	Symbol	Parameter	Conditions				Unit
				Min.	Typ.	Max.	
Total Device							
001	VCC	Permissible Supply Voltage		3		15	V
002	I(LDA)m	Permissible Laser Drive Current (closed control loop)	Control range	-350		-10	mA
003	Idc(VCC)	Supply Current without load path	Closed control loop, I(MDK) = 0, I(LDA) = -350 mA		5	10	mA
004	Ioff(VCC)	Supply Current after Reset			2.4	5	mA
005	I _r (VCC)	Reverse Supply Current	RM = 50 kΩ, VCC = -6 V	-15	-3		mA
006	ton()	Turn-on Delay	VCC: 0 → 5 V to 95% I(LDA), I(LDA) = I(LDA)m, CI = 3.3 μF			600	μs
007	Vc()hi	Clamp Voltage hi at MDA	I() = 10 mA, other pins open	1		4	V
008	Vc()lo	Clamp Voltage lo at VCC, LDA, MDA, CI, VCCA	I() = -10 mA, other pins open	-9			V
009	Vc()hi	Clamp Voltage hi at MDK referenced to VCCA	I() = 10 mA, other pins open	8	11	14	V
010	Vc()lo	Clamp Voltage lo at MDK referenced to VCCA	I() = -10 mA, other pins open	-11		-1	V
011	Vc()hi	Clamp Voltage hi at VCC, LDA, CI, VCCA	I() = 10 mA, other pins open	16		24	V
Reference and Monitor Inputs MDA, MDK, AGND							
101	Vref(MDK)	Reference Voltage at MDK	Vref(MDK) = VCCA - V(MDK), closed control loop, VCC - V(LDA) > Vs(LDA)	1.18	1.24	1.30	V
102	dV(MDK)	Reference Voltage Temperature Drift at MDA	See 101			120	μV/°C
103	Ierr(MDK)	Input Current in MDK	Closed control loop, I(MDA) = 0	-300		300	nA
104	dI(MDK)	Input Current Temperature Drift in MDK	See 103	-1		1	nA/°C
105	APCerr	Control Error	RM = 10 kΩ; Tj = 0...80 °C Tj = -40...125 °C			0.5 2	% %
106	dI(MD)	Supply Voltage Suppression	V(VCC): 3 → 15 V, I(LDA) = -350 mA	-2		2	%
107	Rgnd()	Resistor AGND-GND				3	Ω
108	CR()	Current Ratio I(MDA)/I(MDK)	I(MDA) = 1 μA...1 mA I(MDA) = 1...6 mA	0.98 0.95		1.03 1.05	
109	TC()	Current Ratio Temperature Coefficient I(MDA)/I(MDK)	I(MDA) = 1 μA...1 mA	-0.005 -0.025		0.005 0.025	%/°C %/°C
110	Vf(MDA)	Voltage at MDA	I(MDA) = 1 μA...6 mA	0.4	1.3	2	V
Laser Driver LDA							
201	Vs(LDA)	Saturation Voltage at LDA referenced to VCC	Vs(LDA) = V(VCC) - V(LDA); I(LDA) = -40 mA I(LDA) = -350 mA			0.9 1.3	V V
202	dI(MDK)	Load Balancing Error	I(LDA): -20 → -350 mA	-2.5		2	%
203	I _t (LDA)	Overcurrent Threshold in LDA		-700		-360	mA
204	toff()	Overcurrent Reset Delay	Lack of feedback: I(MD) = 0 to I(LDA) > -10 mA, VCC = 5 V, CI = 3.3 μF			600	μs
205	Vf()	Flyback Diode Forward Voltage V(GND)-V(LDA)	I(LDA) > -350 mA			1.5	V
206	Rvcc()	Transient Protection Resistor	VCC to VCCA			3	Ω
207	Vt(MDK)	Shutdown Threshold at MDK	Vt(MDK) = V(VCCA) - V(MDK), t > 1 μs	1.35		2.1	V
Control Release Flip-Flop							
401	VCCen	Set Threshold for Enable Flip-Flop		0.6		1.9	V
402	Toff	Overtemperature Shutdown		140		165	°C

SAFETY INSTRUCTIONS

Laser light can damage the human eye and the eyes of animals! Do not look at any laser light directly or through any optical lens. When handling a laser diode, do not look directly at the light generated by it. Wear appropriate safety glasses to prevent light from entering the eye even by reflection.



FUNCTION DESCRIPTION

Setting the output power

The output power is simply set by $RM = V_{ref}(MDK) / I(MD)$, where $V_{ref}(MDK) = \text{Item No. 101}$ and $I(MD)$ = the monitor current of the laser diode at the desired operating point. RM should be combined from a fixed resistor (max. output power) and a trimmer (calibration).

Turn-on behaviour

After switching the supply voltage on, the output stage remains disabled until the internal enabling flip-flop is set by a sufficiently high voltage at VCC .

A quick soft start follows; the transition to controlled CW operation is gradual and primarily determined by the values of CI and RM . CI is properly dimensioned when the voltage undershoot at MDK is at a minimum.

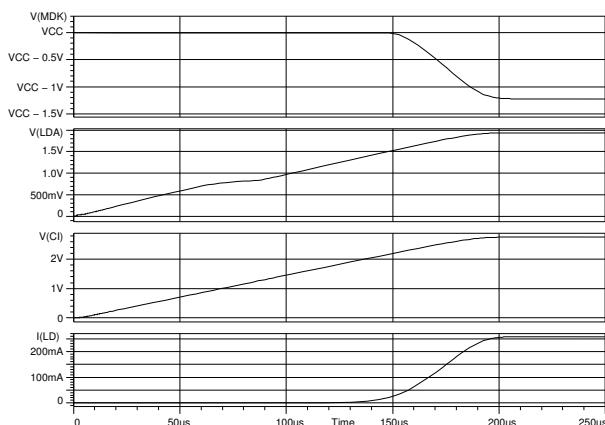

Figure 1: Turn-on behaviour

Turn-off behaviour

iC-WKP works without a fixed undervoltage lockout, thus the laser diode forward voltage is the prime factor determining the lowest possible supply voltage.

If the voltage drops below this value, the output stage is forcibly saturated and the laser current decreases. iC-WKP simultaneously discharges control capacitor CI so that no excessive laser diode currents occur when the supply voltage again rises.

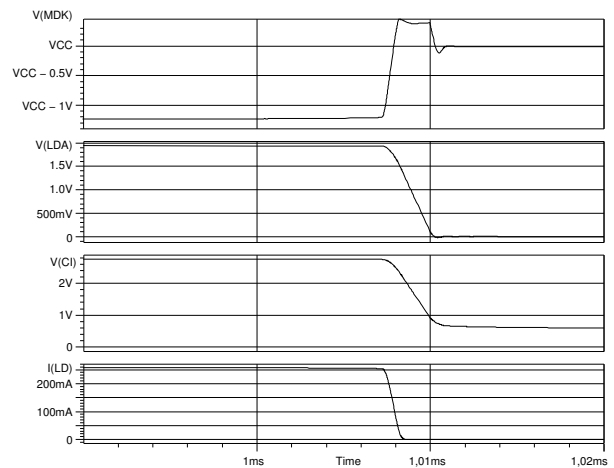

Figure 2: Turn-off behaviour

Disruptions in operation

The power control is shut down with excessive driver temperature or when the laser current reaches the over-current shutdown threshold, for example when the feedback path is interrupted. If the monitor diode or bias resistor RM fail, the device is shut down in less than 600 μs , provided that the supply voltage applied is high enough.

When modulating the laser current via pin MDA , low voltage occurring at pin MDK may also cause a shut-down.

APPLICATION NOTES

Laser diode types

Two laser diode types can be operated by iC-WKP.

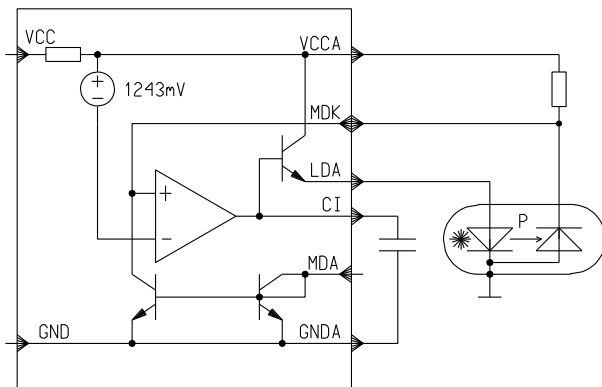

Figure 3: Operation of a **P-type** laser diode

As iC-WKP has been optimised for use with **P-type** laser diodes, it is with this type of diode that the best functionality is achieved. This type of setup also enables the laser diode package to be connected to GND.

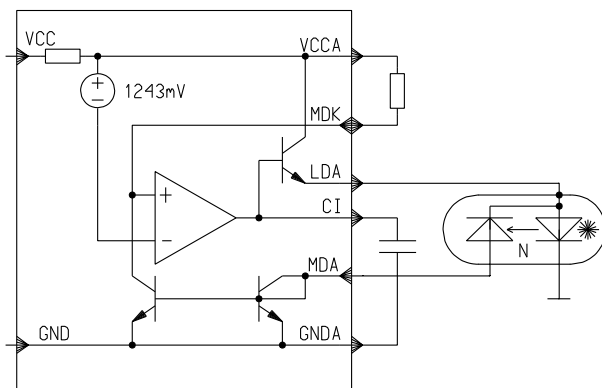

Figure 4: Operation of an **N-type** laser diode

The operation of **N-type** laser diodes it is also possible. Here, however, the current mirror at MDA introduces a certain error to the automatic power control (c.f. Electrical Characteristics Nos. 108–110); **iC-WKN**, which has been optimised for use with these diodes, may be a better choice.

iC-WKP does not allow for the operation of **M-Type** laser diodes. For these laser diode types **iC-WKM** would be the best choice.

Layout

To prevent instability of the regulator an additional capacitor (ca. 100 pF) must be positioned directly at the iC's pin CI. Depending on the laser diode, capacitor CM with typ. 2 nF in parallel with RM may be required for stability. RL may be introduced to improve stability even further and additionally reduce the power dissipation of iC-WKP.

Pin AGND acts solely as a ground reference for the power regulator (CI and RM) and should not be short-circuited with GND externally. This could have a negative effect on the control behaviour and monitor functions.

Cooling

Laser diodes should be sufficiently cooled, particularly with the power-regulated operation of setups which use iC-WKP, for example. The power dissipation in the laser diode otherwise causes the diode to heat up and the level of efficiency to drop which the power control unit then compensates for by increasing the laser current. This in turn brings about a rise in power dissipation in the laser diode and thus also in temperature. In this instance the laser diode could be damaged (resulting in spottiness of the laser beam and an increase in operating current) or even destroyed before the overcurrent shutdown threshold in iC-WKP is reached.

EVALUATION BOARD

iC-WKP comes with an evaluation board for test purpose. Figures 5 and 6 show both the schematic and the component side of the evaluation board.

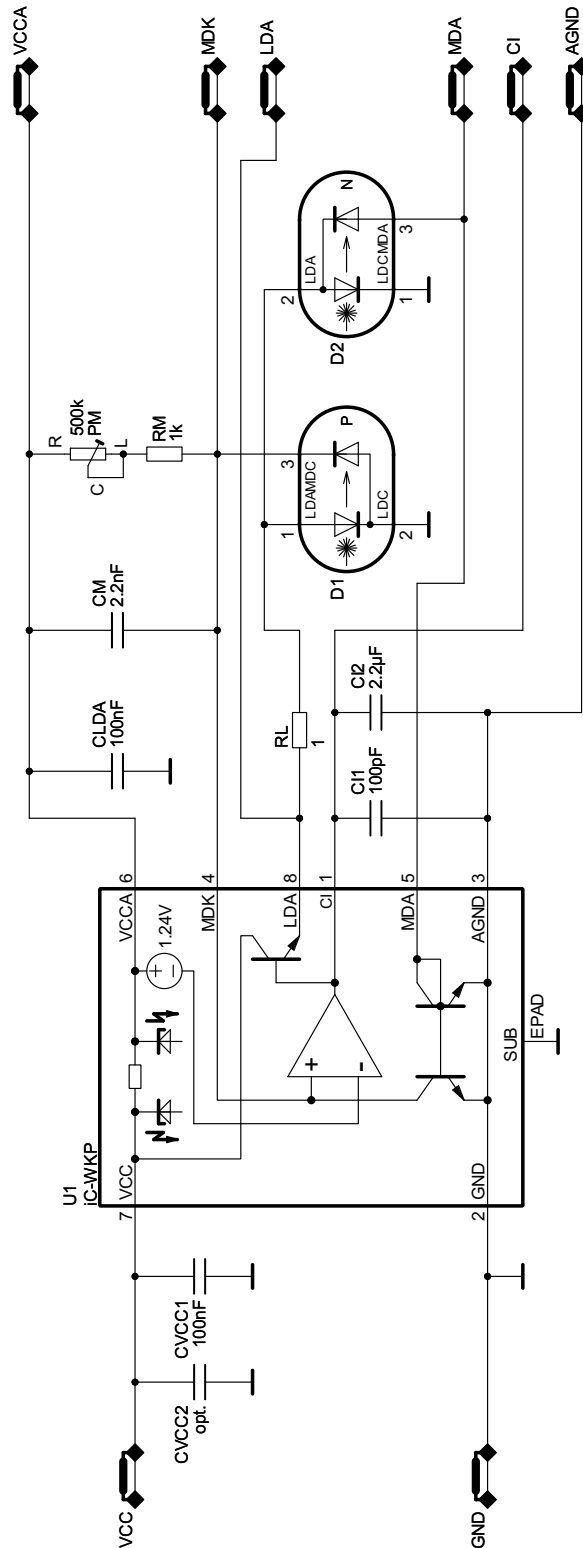

Figure 5: Schematic of the evaluation board

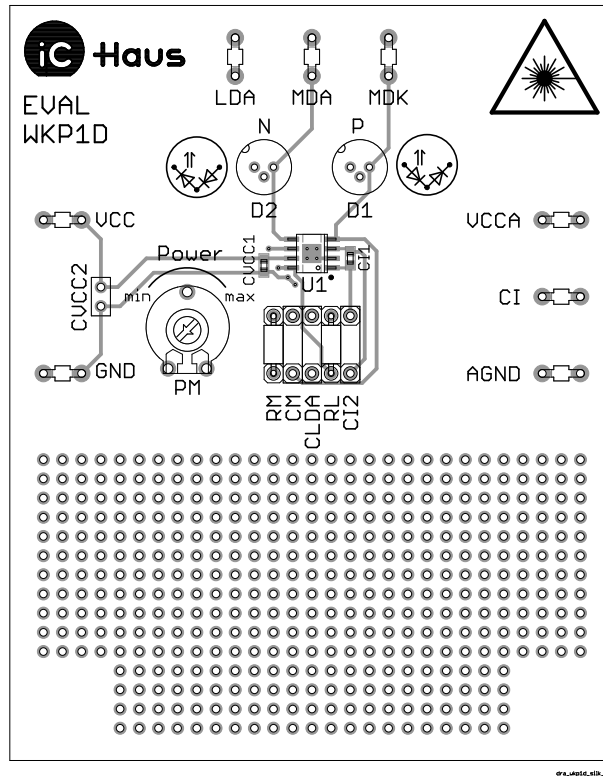

Figure 6: Evaluation board (component side)

REVISION HISTORY

Rel.	Rel. Date*	Chapter	Modification	Page
B1	2024-09-10	PACKAGING INFORMATION	Package dimensions and footprint DFN10 added	5
		ELECTRICAL CHARACTERISTICS	Item No. 108 updated	7

iC-Haus expressly reserves the right to change its products, specifications and related supplements (together the Documents). A Datasheet Update Notification (DUN) gives details as to any amendments and additions made to the relevant Documents on our internet website www.ichaus.com/DUN and is automatically generated and shall be sent to registered users by email. Copying – even as an excerpt – is only permitted with iC-Haus' approval in writing and precise reference to source.

The data and predicted functionality is intended solely for the purpose of product description and shall represent the usual quality and behaviour of the product. In case the Documents contain obvious mistakes e.g. in writing or calculation, iC-Haus reserves the right to correct the Documents and no liability arises insofar that the Documents were from a third party view obviously not reliable. There shall be no claims based on defects as to quality and behaviour in cases of insignificant deviations from the Documents or in case of only minor impairment of usability. No representations or warranties, either expressed or implied, of merchantability, fitness for a particular purpose or of any other nature are made hereunder with respect to information/specification resp. Documents or the products to which information refers and no guarantee with respect to compliance to the intended use is given. In particular, this also applies to the stated possible applications or areas of applications of the product.

iC-Haus products are not designed for and must not be used in connection with any applications where the failure of such products would reasonably be expected to result in significant personal injury or death (*Safety-Critical Applications*) without iC-Haus' specific written consent. Safety-Critical Applications include, without limitation, life support devices and systems. iC-Haus products are not designed nor intended for use in military or aerospace applications or environments or in automotive applications unless specifically designated for such use by iC-Haus. iC-Haus conveys no patent, copyright, mask work right or other trade mark right to this product. iC-Haus assumes no liability for any patent and/or other trade mark rights of a third party resulting from processing or handling of the product and/or any other use of the product.

Software and its documentation is provided by iC-Haus GmbH or contributors "AS IS" and is subject to the ZVEI General Conditions for the Supply of Products and Services with iC-Haus amendments and the ZVEI Software clause with iC-Haus amendments (www.ichaus.com/EULA).

* Release Date format: YYYY-MM-DD

ORDERING INFORMATION

Type	Package	Order Designation
iC-WKP	SO8-TP	iC-WKP SO8-TP
iC-WKP	DFN10 4 mm x 4 mm	iC-WKP DFN10
Evaluation Board		iC-WKP EVAL WKP1D

Please send your purchase orders to our order handling team:

Fax: +49 (0) 61 35 - 92 92 - 692

E-Mail: dispo@ichaus.com

For technical support, information about prices and terms of delivery please contact:

iC-Haus GmbH
Am Kuemmerling 18
D-55294 Bodenheim
GERMANY

Tel.: +49 (0) 61 35 - 92 92 - 0
Fax: +49 (0) 61 35 - 92 92 - 192
Web: <https://www.ichaus.com>
E-Mail: sales@ichaus.com

Appointed local distributors: https://www.ichaus.com/sales_partners