

# 803-A-111-SMD

PCB connector for SMD  
Push-In connection

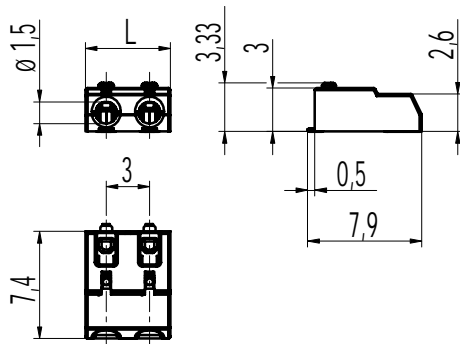

### PCB Layout (Recommendation)

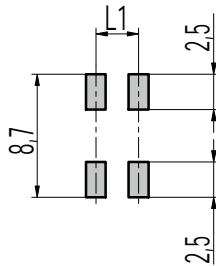

$L1 = (\text{No. of poles} - 1) \times \text{pitch}$   
Solder paste thickness: 0,15 - 0,2 mm

### Part Numbers

No. of poles	803-A-111-SMD	Length	PU
1		2,90 mm	
2		5,90 mm	
3		8,90 mm	

### General Information

Pitch	3 mm
No. of poles	1 - 3
Areas of application	Lighting technology, devices

### Technical Data

Clamping Range	<i>solid / flexible / AWG</i> 0,14 - 0,34mm <sup>2</sup> / 0,14 - 0,34mm <sup>2</sup> / 26 - 22 AWG [1]		
Rated Cross Section	0,2 mm <sup>2</sup>		
Wire Stripping Length	5 mm ± 0,5 mm		
Overvoltage Category	III	III	II
Pollution Severity Level	3	2	2
Rated Voltage	32 V	125 V	160 V
Rated Impulse Voltage	1,5 kV	1,5 kV	1,5 kV
Rated Current	4 A (AWG 22) 3 A (AWG 24) 2,5 A (AWG 26)		
Soldering process	Reflow solder		

### Material

Moulding	PA HT, natural, V-0
Comparative Tracking Index	CTI ≥ 600
Insulating Group	I
Temperature Range	RTI Str 130°C; reflow solder temperature (Peak) max. 260°C ( max. 10 s)
Terminal body	Tin plated copper alloy
Spring	Tin plated copper alloy

### Approvals

	Current [A]	Voltage [V]	Group	AWG	[Nm]
	3	250		26 - 22	

UL certification pending

### Part Numbers: Tape-on-Reel

No. of poles	803-A-111-SMD	Tape Width	Tape Height	PU
1	10.813.301.A00	16 mm	4,1 mm	2200
2	10.813.302.A00	16 mm	4,1 mm	1400
3	10.813.303.A00	16 mm	4,1 mm	1400

[1] Use of flexible conductors only with tinned ends