

308-PA/..-401, 308-PAG/..-401

Distributor strip

Tab connections 5 x 6,3 & Screw connection; inclined

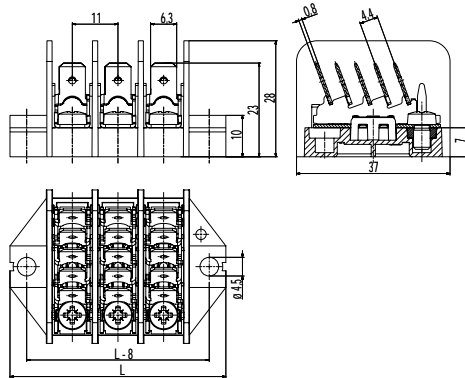
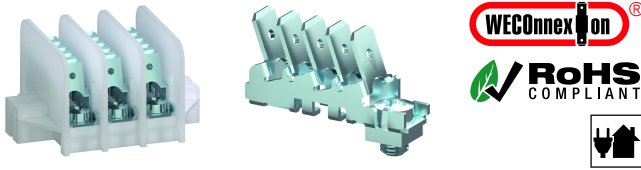

Part Numbers

No. of poles	308-PA/..-401	308-PAG/..-401	Length	PU
1	11.885.401	11.888.401	30	250
2	12.885.401	12.888.401	41	200
3	13.885.401	13.888.401	52	200
4	14.885.401	14.888.401	63	100
5	15.885.401	15.888.401	74	100
6	16.885.401	16.888.401	85	100
7	17.885.401	17.888.401	96	100
8	18.885.401	18.888.401	107	50
10	20.885.401	20.888.401	129	50
12	22.885.401	22.888.401	151	50

further number of poles on request

General Information

Pitch	11 mm
No. of poles	1 - 16



Technical Data

Clamping Range	<i>solid / flexible / AWG</i> 0,5 - 1,5 mm ² / 0,5 - 1,5 mm ² / 20 - 16 AWG [1][2]
Rated Cross Section	1,5 mm ² [3]
Wire Stripping Length	10 mm ± 0,5 mm
Rated Insulation Voltage	450 V acc. to EN 60998-1
Rated Current	10 A with receptable 6,3; wire 1,5 mm ² 16 A with receptable 6,3; wire 2,5 mm ² 20 A with receptable 6,3; wire 4 mm ² 25 A with receptable 6,3; wire 6 mm ² 17,5 A with screw connection; wire 1,5 mm ²
Torque	1,7 Nm
Other specifications	Screw terminals are generally suitable for wires with identical wire type / cross-section.

Material

Moulding	PA, natural, V-2 (PAG-Version: PA GF, natural, V-0) Details in brackets apply for "no flame" products
Comparative Tracking Index	CTI 250 (CTI 400)
Insulating Group	IIIa (II)
Temperature Range	RTI Str 90°C (130°C PAG-Version)
Tab	Zinc plated steel
Screw	M4; Zinc plated steel, blue passivated
Square washer	M4; Zinc plated steel

Approvals

	Current [A]	Voltage [V]	Group	AWG	[Nm]
	20	300	B	14 - 12 [4]	1,7
	10	300	D	14 - 12 [4]	1,7
	Current [A]	Voltage [V]	[mm ²]		
	17,5	450	1,5		

Options / Accessories

- Consecutive numbering
- Special marking according to drawing
- Fixed marking in the tool on request
- Jumper VB-308

- [1] Per pole two wires of identical cross-section can be connected
 [2] Ferrules are required when using flexible or multi-stranded wires
 [3] Screw connection
 [4] AWG specifications refer to tab connections